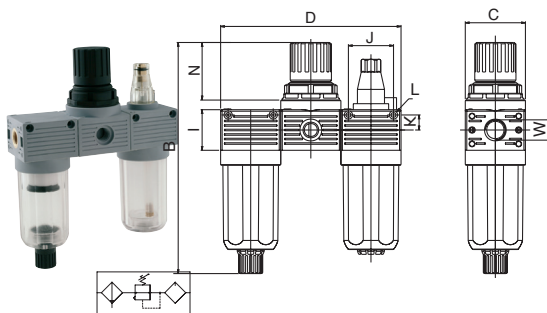

T200 Mini

F + R + L

CODICI DEI PRODOTTI STANDARD A MAGAZZINO-STANDARD PRODUCTS AVAILABLE IN STOCK

Codice Code	Misura Size	Filetto Thread	Filtrazione Filtration	Regolazione Regulation	Portata Flow Rate
T200002231100	F+R+L 0	1/8	20µm	0-8 bar	280 NI/min
T200003231100	F+R+L 0	1/4	20µm	0-8 bar	280 NI/min

Dimensioni - Dimensions

B	C	D	I	J	K	L	N	W
156	40	120	27	30	10	Ø X M3	40	1/8 - 1/4

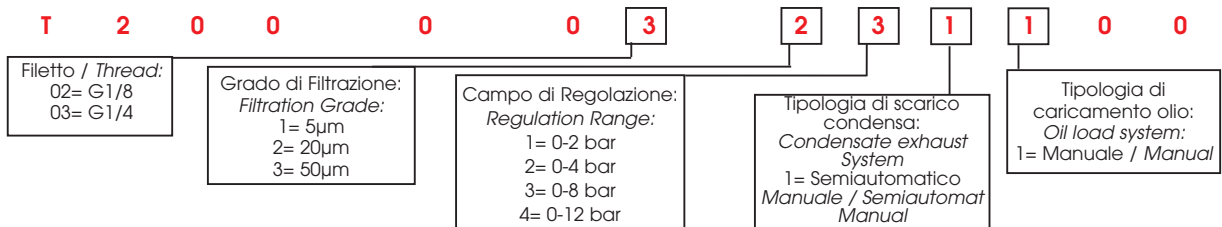
Tabella dei codici di ordinazione / Article codes to be used for ordering

Caratteristiche Tecniche - Technical Characteristics

FLUIDO / FLUID
 ATTACCO FILETTATO / THREADED FASTENING
 GRADO DI FILTRAZIONE / FILTRATION GRADE
 CAMPO DI REGOLAZIONE / REGULATION RANGE
 PORTATA A 6 BAR CON Δp 1 bar
 6 bar FLOW RATE WITH Δp 1 bar
 PRESSIONE MAX / MAXIMUM PRESSURE
 TEMPERATURA / TEMPERATURE
 VITI DI FISSAGGIO / WALL CLAMPING SCREWS
 POSIZIONE DI MONTAGGIO / ASSEMBLING POSITION
 OLII CONSIGLIATI / RECOMMENDED OILS

ARIA COMPRESSA / COMPRESSED AIR
 1/8" -1/4"
 5µm - 20µm STANDARD - 50µm
 0-2 bar 0-4 bar 0-8 bar STANDARD 0-12 bar
 280 NI/min
 15 bar
 -10 / 50°C
 M3
 VERTICALE / VERTICAL
 CLASSE ISO VG 22A NORMA ISO 3448