

PG



MATERIALS

Head:
Aluminium alloy

Bowl:
Steel

Bypass valve : NBR Nitrile
(FKM - on request fluoroelastomer)

Seals:
NBR Nitrile
(FKM - on request fluoroelastomer)

Indicator housing:
Brass

PRESSURE (ISO 10771-1:2002)

Max working:
5 MPa (50 bar)

Fatigue test:
0-5 Mpa (0-50 bar) 1 million cycles

Collapse, differential
for the filter element (ISO 2941):
1 MPa (10 bar)

BYPASS VALVE

Setting: 350 kPa (3,5 bar) $\pm 10\%$

WORKING TEMPERATURE

From -25° to $+110^{\circ}$ C

COMPATIBILITY (ISO 2943:1999)

Full with fluids: HH-HL-HM-HV-HTG
(according to ISO 6743/4)
For fluids different than the above
mentioned, please contact our Sales
Department.

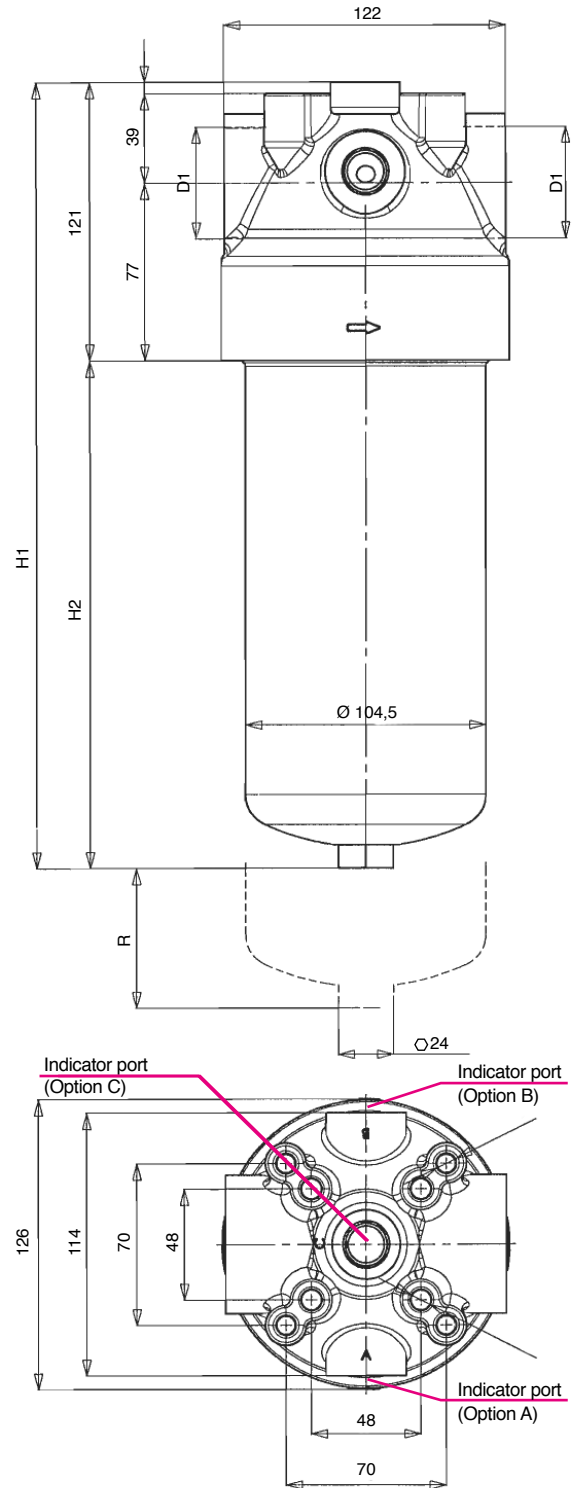
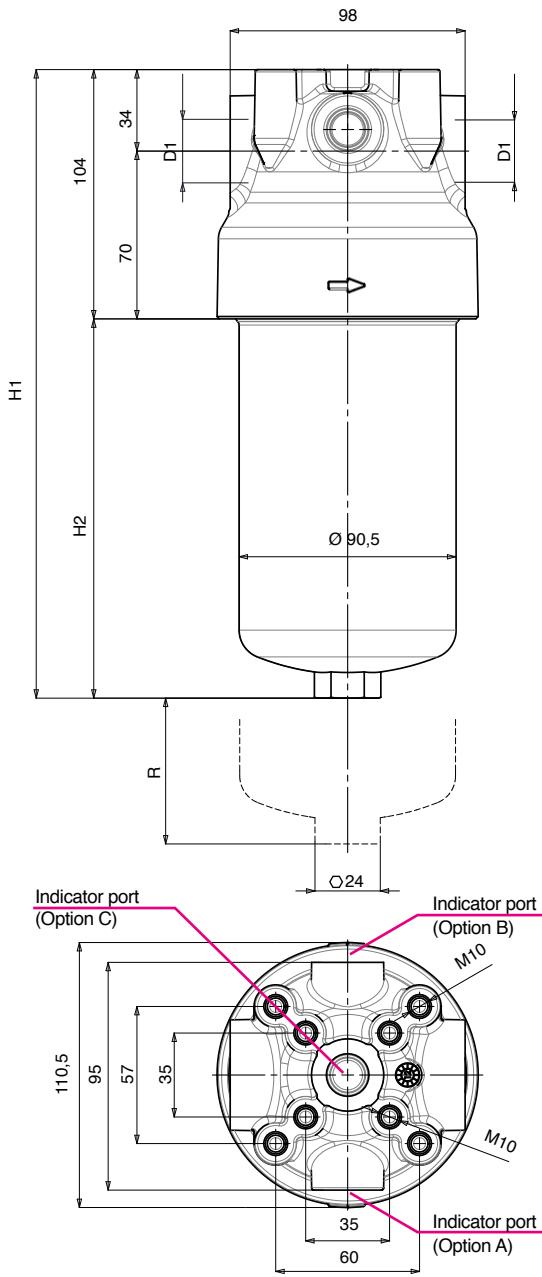

FILTER HOUSING

	D1	H1	H2	R	kg
FPG20	3/4" - 1"	202	98	70	2,00
FPG21	3/4" - 1"	262	158	70	2,25
FPG22	3/4" - 1"	342	238	70	2,80
FPG31	1" 1/4 - 1" 1/2	341	220	70	3,50

F F = FILTER COMPLETE					ELEMENT										
P	G	FAMILY, NOMINAL SIZE & LENGTH				20	21	22	31	FAMILY SIZE & LENGTH	P	G			
B PORT TYPE					SEALS										
B = BSP					B	B	B	B	N = Nitrile NBR	N	N	N	N		
PORT SIZE (quote D1)					D = bypass valve 3,5 bar					F = FPM					
06 = 3/4"					06	06	06	-	W = without			W	W	W	W
08 = 1"					08	08	08	-	D = bypass valve 3,5 bar			D	D	D	D
10 = 1" 1/4					-	-	-	10							
12 = 1" 1/2					-	-	-	12							
SEALS					SEALS										
N = Nitrile NBR					N	N	N	N	N = NBR						
F = Fluoroelastomer FPM					F	F	F	F	F = FPM						
FILTER MEDIA					FILTER MEDIA										
FA = fiber 5 μm_(c) β>1.000					FA	FA	FA	FA	FA = fiber 5 μm_(c) β>1.000						
FB = fiber 7 μm_(c) β>1.000					FB	FB	FB	FB	FB = fiber 7 μm_(c) β>1.000						
FC = fiber 12 μm_(c) β>1.000					FC	FC	FC	FC	FC = fiber 12 μm_(c) β>1.000						
FD = fiber 21 μm_(c) β>1.000					FD	FD	FD	FD	FD = fiber 21 μm_(c) β>1.000						
CC = cellulose 10 μm β>2					CC	CC	CC	CC	CC = cellulose 10 μm β>2						
CD = cellulose 25 μm β>2					CD	CD	CD	CD	CD = cellulose 25 μm β>2						
MC = metal wire mesh 10 μm					MC	MC	MC	MC	MC = metal wire mesh 10 μm						
MD = metal wire mesh 30 μm					MD	MD	MD	MD	MD = metal wire mesh 30 μm						
ME = metal wire mesh 60 μm					ME	ME	ME	ME	ME = metal wire mesh 60 μm						
MF = metal wire mesh 90 μm					MF	MF	MF	MF	MF = metal wire mesh 90 μm						
CLOGGING INDICATORS															
00 = no indicator port					00	00	00	00							
03 = indicator port, plugged					03	03	03	03							
5D = differential 2,5 bar, visual					5D	5D	5D	5D							
6D = differential 2,5 bar, electrical					6D	6D	6D	6D							
7D = differential 2,5 bar, electrical + LED					7D	7D	7D	7D							
76 = differential 2,5 bar, electrical + visual					76	76	76	76							
T6 = differential 2,5 bar, electrical with Thermostat 30°C					T6	T6	T6	T6							
ACCESSORIES															
W = no indicator port					W	W	W	W							
A = indicator port left side					A	A	A	A							
B = indicator port right side					B	B	B	B							
C = indicator port on the top					C	C	C	C							
X ACCESSORIES															
X = no accessory available					X	X	X	X							

FILTER ELEMENT

	A	B	C	Area (cm ²)		
				Media F+	Media C+	Media M+
EPG20	78	30	100	1.300	1.500	1.000
EPG21	78	30	160	2.200	2.550	1.700
EPG22	78	30	240	3.300	3.900	2.600
EPG31	92	40	215	4.700	5.100	3.500

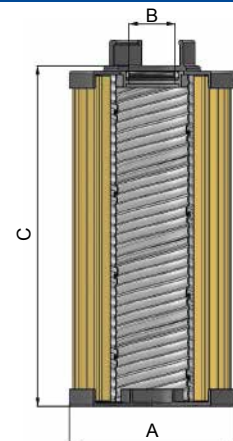

FLUID SPEED

when selecting the filter size, we suggest to consider also the max recommended fluid speed (in pressure lines normally $5 < v < 10$ m/s).

RECOMMENDED FLOW RATES

Type	Filter Media	Δp 80 kPa (0,8 bar)
FPG 20	FA	55
	FB	70
	FC	80
	FS	85
	FD	90
	CC	105
	CD	115
	MC	130
	MD	130
	ME	150
	MF	150

Type	Filter Media	Δp 80 kPa (0,8 bar)
FPG 21	FA	80
	FB	105
	FC	120
	FS	125
	FD	130
	CC	150
	CD	150
	MC	150
	MD	150
	ME	150
	MF	150

Type	Filter Media	Δp 80 kPa (0,8 bar)
FPG 22	FA	90
	FB	130
	FC	150
	FS	150
	FD	150
	CC	150
	CD	150
	MC	150
	MD	150
	ME	150
	MF	150

Type	Filter Media	Δp 80 kPa (0,8 bar)
FPG 31	FA	260
	FB	270
	FC	310
	FS	340
	FD	360
	CC	400
	CD	400
	MC	400
	MD	400
	ME	400
	MF	400

N.B. All the data have been obtained with mineral oil having a kinematic viscosity 30 cSt and specific gravity 0,9 kg/dm³; for fluids with different features, please consider the factors described in the first part of this catalogue. All the data are obtained from test done at the UFI HYDRAULIC DIVISION Laboratory, according to the specification ISO 3968:2005. In case of discrepancy, please check the contamination level, viscosity and features of the fluid in use.

CLOGGING INDICATOR

For further technical informations and other options see General Catalogue.

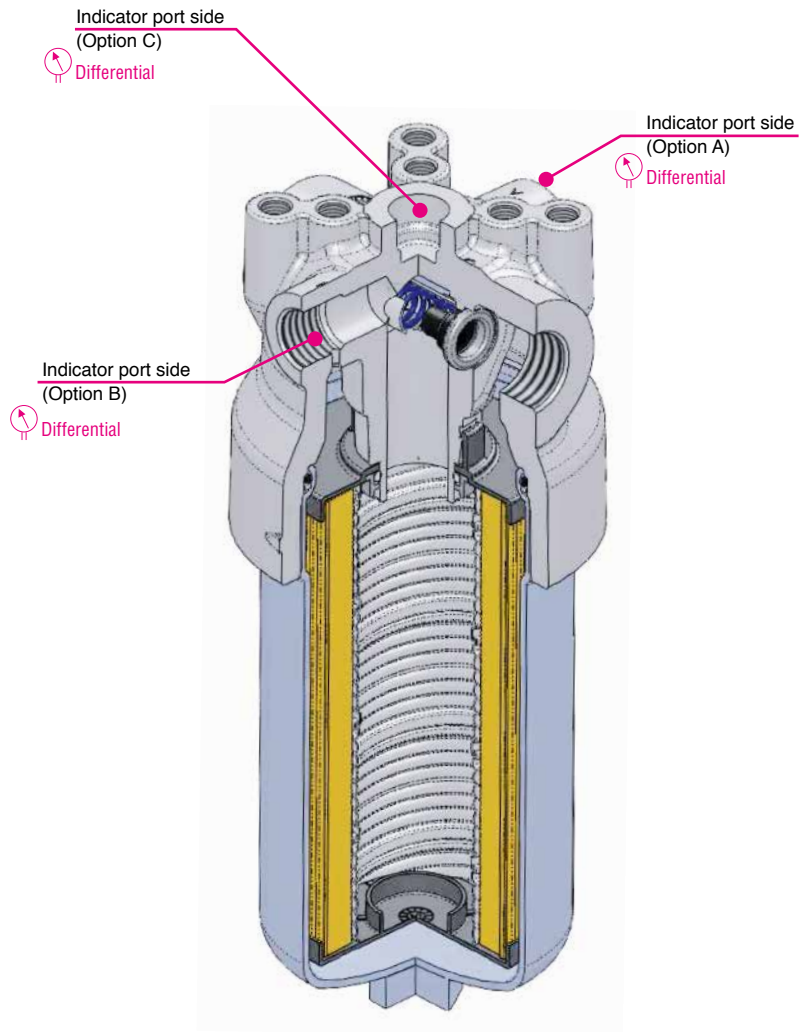
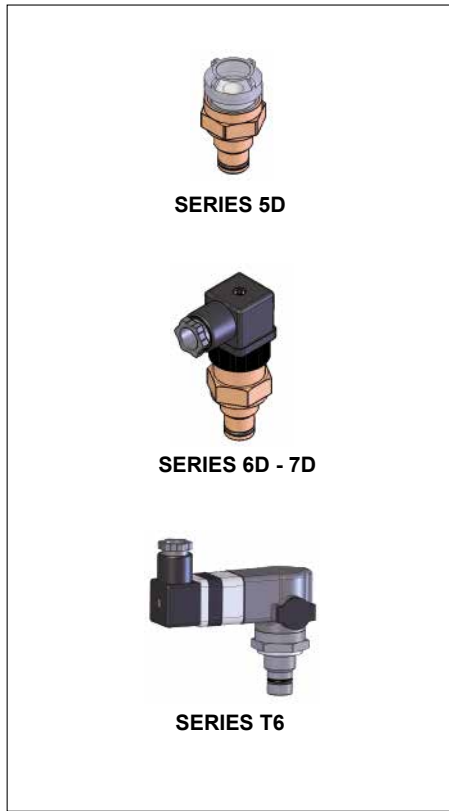

SPARE SEAL KIT

	NBR	FKM
FPG20	521.0117.2	521.0118.2
FPG21	521.0117.2	521.0118.2
FPG22	521.0117.2	521.0118.2
FPG31	521.0119.2	521.0120.2

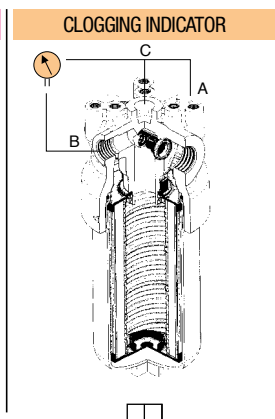
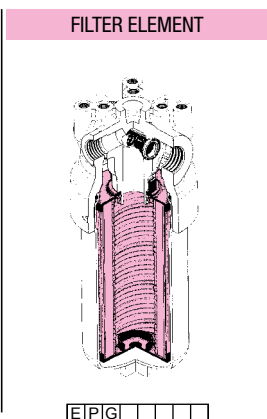
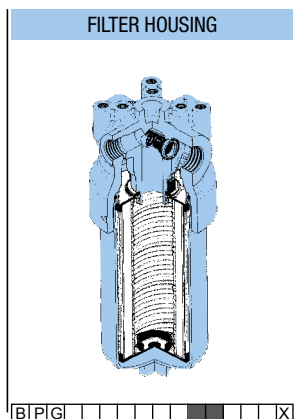

SPARE PARTS ELEMENTS
(For filling up see table
"Ordering and option chart")

Technical data subject to variations without prior notice. PG - EN - 07/2014



Is this datasheet the latest release? Please check on our website.

