

# Load-holding valves type LHDV

with special oscillation dampening, zero leakage

Operating pressure  $p_{max} = 420 \text{ bar}$ ; Flow  $Q_{max} = 80 \text{ lpm}$

## 1. General

These valves are pressure valves according to the Industrial Standard DIN ISO 1219-1. They prevent pulling or pushing loads from accelerating uncontrollably during movements in load direction, or from proceeding with higher speed than intended i.e. determined by the inflowing oil on the pump's side. Consequently, these devices prevent a collapse or eventual rupture of the oil column. The main application for load-holding valves is with hydraulic lifting-, pivoting-, turning- or similar constructions which utilize double acting consumers (hydraulic cylinders, hydraulic motors).

This is accomplished by throttling of the return flow from the corresponding consumer. The load-holding valves generates a flow resistance, which is always a little bit higher than the pressure created from the load. This back pressure is only generated under negative load conditions. But the valve will be fully opened, enabling free flow (return) if the load is positive, i.e. the load acts against the direction of the motion.

The throttle device is self-adjusting and therefore adapts continuously to any alternation of the load condition. This is achieved by an equilibrium of forces between the outflow and inflow (from the actuated consumer) acting on the functional valve elements on the one side, and the valve spring acting on the other side.

The valves version LHDV are especially designed for those applications, which, due to their own elasticity, tend heavily towards pendulum oscillations. The load-holding valves are most advantageous when utilized in conjunction with prop. directional spool valve banks, functioning according to the Load-Sensing-Principle which do have 2-way inflow control valves in each valve bank section. Consequently, they should be installed in the corresponding lines between consumer and directional spool valve.

As a self-contained unit, the LHDV-valve permits the specific intervention into the oscillating circle, as it is created by hydraulic cylinders with attached load, the flow control valves of the directional spool valves, or the pressure/flow regulator of variable displacement pump. Its dampening abilities are significantly more adaptable and their effect more accurately adjustable than would be possible with common measurements, e.g. through modification (distortion) of the characteristic curve of the flow control valves installed in prop. directional spool valves.

The fluctuating load pressure influences the motion of the control device which varies the throttle area. But its response is slightly delayed, slowed and weakened by a combination of especially designed damping elements. This will successfully intercept the pendulum motions being evoked, which are induced by starting, stopping, or sudden transitions from full speed to crawl speed. They will be eventually suppressed in their developing stage, by letting them fade away quickly. For a detailed functional description and notes for customizing the damping, especially for critical conditions, see B 7770.

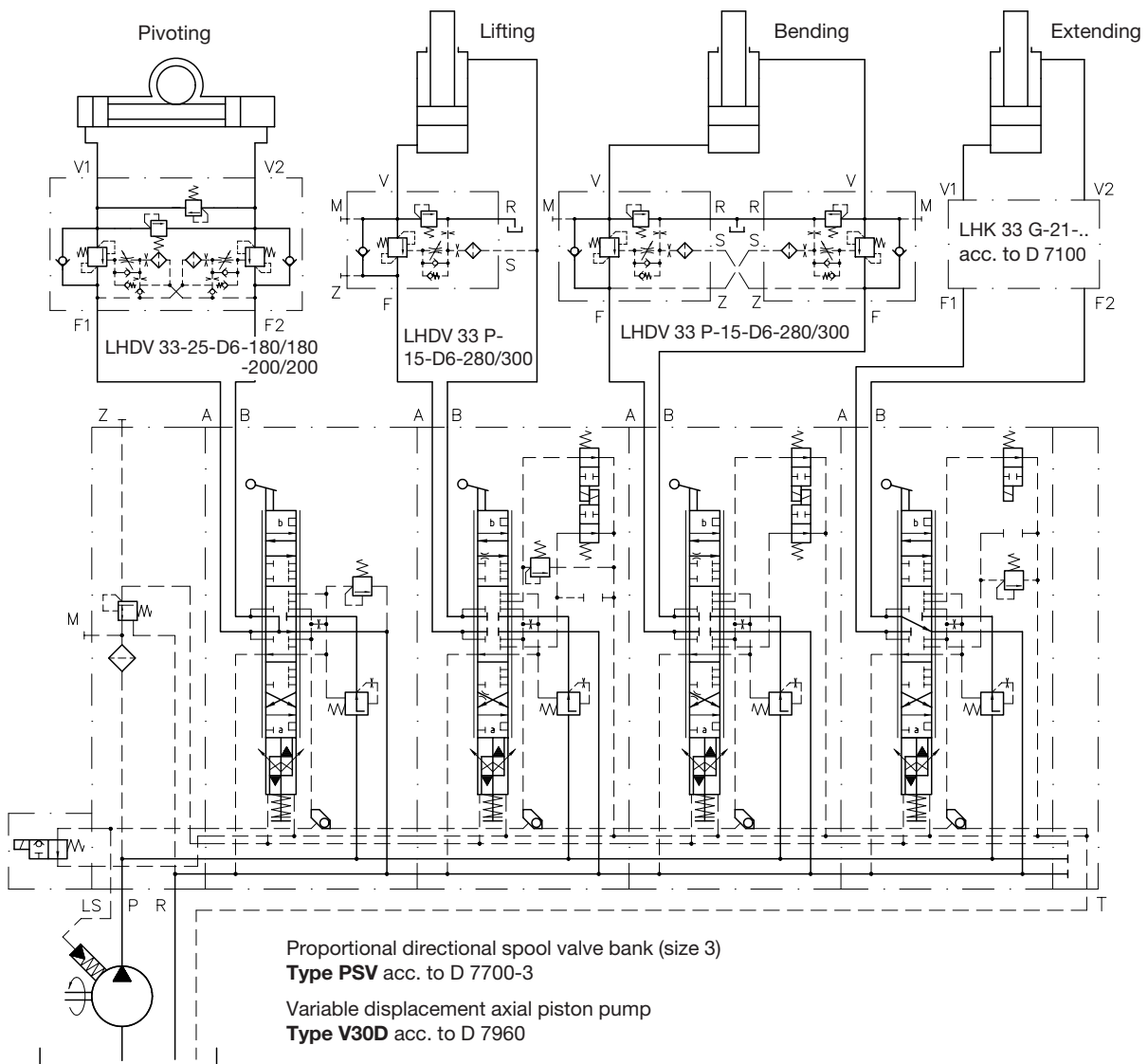

## 2. Available versions, main data

Order examples: **LHDV 33 P - 15 - B 6 - 300/320**

Desired pressure setting (bar) within the permissible pressure range, acc. to sect. 3  
For correct positioning of pressure figures for the load holding valve, and eventual shock valve see following examples.

**Table 3:** Orifice combinations (orifice D1 - without coding = 0.5 mm)

Coding	Orifice 2					
	4	5	6 (Standard)	7	8	0
Ø (mm)	0.4	0.5	0.6	0.7	0.8	0 (no hole)
Release ratio	1: 6.3	1: 4.45	1: 2.9	1:1.84	1:1.18	1: 8.2 <sup>1)</sup>

<sup>1)</sup> The actual release ratio corresponds to the geometric ratio

**Table 2:** Flow adaptation

Adjustable pressure ranges p <sub>max</sub> (bar)	(50) ... 350 351 ... 420	A	B	C	D	E	<sup>2)</sup> With positively acting load, i.e. during lifting, one can expect a Δp of approx. 50 bar with the max. permissible flow rates. This pressure has to be added to the load pressure.
		L	M	N	P	R	
Max. flow V→F Q <sub>max</sub> approx. (lpm) valve fully opened <sup>2)</sup>		80	60	40	25	16	
							See also the Δp-Q curves in sect. 3, this applies also to the flow / back pressure V→F with positive load (valve completely open)

**Table 1:** Basic type, size, and additional elements

Flow pattern symbols, for illustration see sect. 2.1	Basic type Design	Single valves for constant load directions	Double valves for alternating load direction			
			Without additional elements	With shuttle valves for the pressure signal port X(T)		
				With by-pass check valve in port X		With suction port T (volume balance)
	Standard <b>11</b> <sup>3)</sup>	<b>21</b>	<b>21W</b>	<b>21WD</b>	---	---
	With unpressurized control piston	---	<b>21L</b>	<b>21WL</b>	---	---
	With add. shock-valves	<b>25</b>	<b>25W</b>	<b>25WD</b>	<b>25WDN</b>	
	With unpressurized control piston	---	<b>25L</b>	<b>25WL</b>	<b>25WDL</b>	<b>25WDNL</b>
<b>LHDV 33 -</b>	Pipe connection <sup>4)</sup>	---	●	●	●	●
<b>LHDV 33 P -</b>	Manif. mounting, cons. side	●	<sup>3)</sup> Port Z is unplugged ex-works (see following flow pattern symbol). It may be blocked later, if not required by a tapped plug DIN 908-G 1/4 A-St with seal ring 14x18x1.5 DIN 7603-CU <sup>4)</sup> ISO 228/1 (BSPP)			
<b>LHDV 33 H -</b>	Banjo bolt mounting, consumer side	●				
<b>LHDV 33 H 1/2 -</b>	M22x1.5 metric fine thread DIN 13 T6 G 1/2 A <sup>4)</sup>	●				

### 2.1 Additional order examples with corresponding flow pattern symbols

#### Single valves for always constant load direction

Release for direction V→F during lowering of the load via an external control line at port S from the other side (inflow consumer line).

Order examples of available versions:

Selected pressure setting (bar)  
load holding valve

#### LHDV 33 P - 11 - C6 - 280

Basic type, currently only available for manifold mounting (consumer side). For an adapter plate, enabling pipe connection on the consumer side, see sect. 4, page 5

Load holding valve } Selected pressure setting (bar)  
Shock valve }

#### LHDV 33 P - 15 - B6 - 300/320

Version with shock valve, currently only available for manifold mounting (consumer side). For an adapter plate, enabling pipe connection on the consumer side, see sect. 4, page 5.

#### LHDV 33 H - 15 - A6 - 200/240

Version with shock valve, mounted by banjo bolt H = M 22x1.5 or H 1/2 - G 1/2 A (consumer side). It may be installed in any angel concentric around the V-port. A centering predestal is required at the mounting area, see dimensional drawings sect. 4

LHDV 33 P(H) - 11

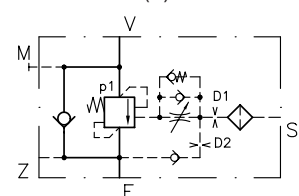

LHDV 33 P(H) - 15

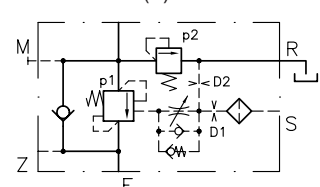

**Double valve for alternating load directions**

The release of the respective reflow side V1→F1 or V2→F2 takes place via internal control oil ducts.  
No external control pipes are required.

Order examples of available versions:

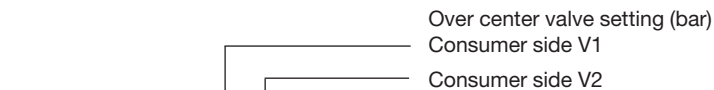

**LHDV 33 - 21 - A6 - 240/180**

Basic version for all applications, where no high pressure peaks or sudden user stops (shock pressure) are expected.

**LHDV 33 - 21L - A6 - 240/180**

Like the above basic version, but with additional port for leakage oil (see also notes in sect. 5.2).

**LHDV 33 - 21W(WD) - A6 - 240/180**

Like the above basic version, but with additional shuttle valve (see also description of type LHDV 33 - 25W(WD) )

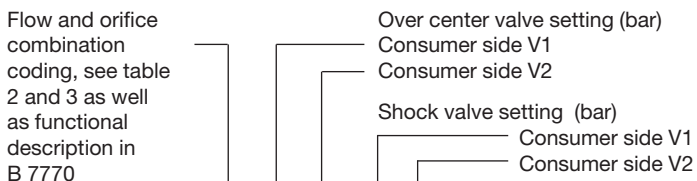

**LHDV 33 - 25 - D5 - 220/220 - 260/260**

Basic version with shock valves e.g. for consumers with a piston area ratio of 1:1.

Flow pattern symbol for version LHDV 21-25L with additional oil leakage port, similar to LHDV 33 - 21L...

**LHDV 33 - 25W - A6 - 250/250 - 300/300**

Like the basic version 25, but with additional shuttle valve, e.g. for brakes with hydraulic release (port X). Preferably used for hydraulic motors.

Flow pattern symbol for version LHDV 33-25WL with additional leakage port, similar to LHDV 33 - 21L...

**LHDV 33 - 25WD - C6 - 100/140 - 130/180**

Like version 25 W, but with additional by-pass check valve type BC1-40 E acc. to D 6969 B mounted at port X (intended to prevent sudden kicking-in of the brake).

Flow pattern symbol for version LHDV 33-25 WDL with additional leakage port, similar to LHDV 33 - 21L...

**LHDV 33 - 25WDN - B6 - 200/200 - 240/240**

Like version 25 WD, but with additional suction valve No. 7770 040 intended for hydraulic motors to balance volumes, altered by leakage. Symbol for version LHDV 33 -25 WDNL with additional leakage port, similar to LHDV 33 - 21L...

**LHDV 33 - 21 - A6 - 240/180**

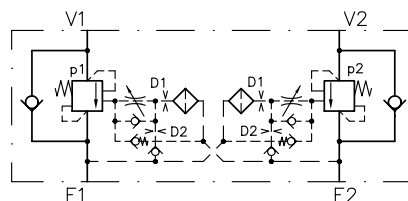

**LHDV 33 - 21 L - A6 - 240/180**

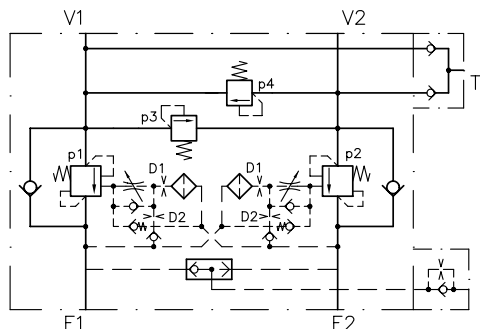
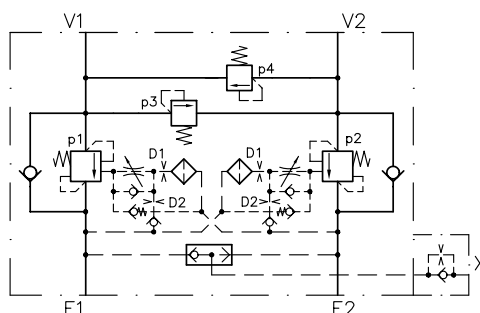
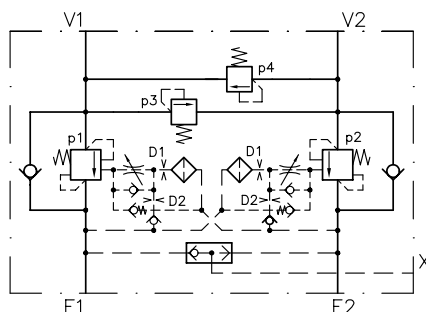
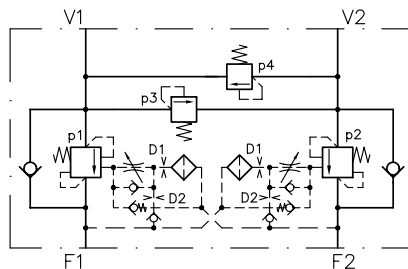
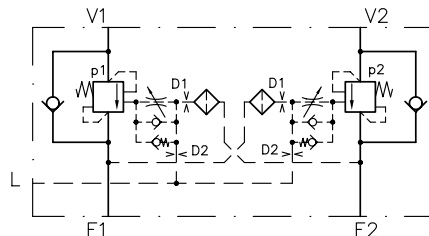

### 3. Further characteristic data

Designation	Load holding valve (over center valve), with hydraulic release and by-pass check valve		
Valve design	Load holding valve: cone seated piston valve By-pass check valve: disk seated valve		
Installed position	Any		
Ports	F, F1, F2, V, V1, V2 and R	Main ports M, S, Z Control- and probing ports depending on version	
Mass (weight) approx.	Type	LHDV 33 P-11 = 1.3 kg LHDV 33 P-15 = 1.8 kg <sup>1)</sup> LHDV 33 H-11 = 1.7 kg LHDV 33 H-15 = 2.2 kg	LHDV 33-21(21W) = 3.5 kg LHDV 33-21L (21WL) = 3.5 kg LHDV 33-21WD = 3.6 kg LHDV 33-25 (L, W, WL) = 3.9 kg
			LHDV 33-25WD = 4.0 kg LHDV 33-25WDN = 4.7 kg LHDV 33-25WDNL = 4.8 kg
		<sup>1)</sup> Corresponding connection block No. 7770 024 = 0.4 kg	

Flow direction Working direction (load holding function) V→F, V1→F1 or V2→F2  
free flow F→V, F1→V1, F2→V2

Release ratio approx. 1:8.2 with closed valve (geometrical ratio)  
approx. 1:1.2 to 1:6.4 with open (unlocked) valve, depending on the orifice diameter ratio, see sect. 2, table 3

Pressure adjustment A pressure gauge should be used whenever the pressure setting is adjusted or altered! The given figures for pressure alternation per rotation or per mm adjustment travel of the perforated disc within the connector F (F1 and F2) are only a rough guide line for approximately achieving the desired setting (start of operation). The setting should be at least 10% above the max. expected load pressure.

Alternation of pressure approx.:		per turn	per mm approx.
Load holding valve	pressure range 50 ... 250 bar	45 bar	25 bar
	pressure range 251 ... 350 bar	50 bar	27.5 bar
	pressure range 351 ... 420 bar	62 bar	34 bar
Shock valve	pressure range 50 ... 450 bar	106 bar	80 bar

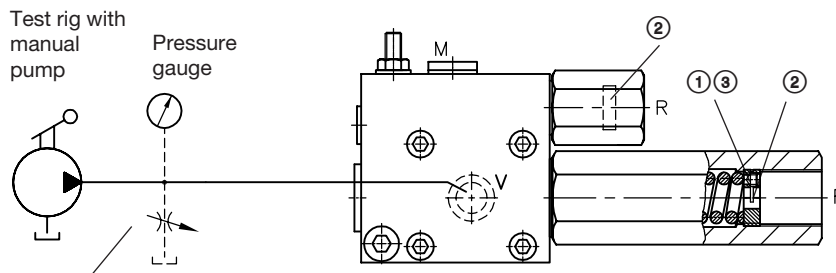

- ① The grub screw, serves for locking of ② and must be loosened prior to any pressure adjustments
- ② Perforated disc can be rotated with Allan Key  
a/f 6 - Load holding valve  
a/f 5 - Shock valve
- ↻ = Pressure increases  
↺ = Pressure decreases
- ③ Retighten the grub screw ① after performed adjustment

This bypass-throttle valve is necessary with test rigs using a motor pump! The pump should be circulating via open throttle valve, then close the throttle valve slowly until LHDV starts barely responding (avoid larger flow since the valve might squeal).

Pressure fluid Hydraulic oil according to DIN 51 524, table 1 to 3; ISO VG 10 to 68 according to DIN 51 519  
range of viscosity: min. approx. 4; max. approx. 1500 mm<sup>2</sup>/sec; optimum range: approx. 10...500 mm<sup>2</sup>/sec. Also usable for biodegradable pressure fluids of the type HEPG (Polyalcynglycol) and HEES (synthetic ester) at operating temperatures < +70°C.

Temperatures Ambient: approx. -40... +80°C  
Fluid: -25... +80°C, but pay attention to viscosity  
Starting temperature down to -40°C admissible (watch starting viscosity!), when the operating temperature during following operation is at least 20 K higher.  
Biological degradable pressure fluids: Observe manufacturer's specifications. Considering the compatibility with seal material not over < +70°C.

Δp-Q-curves The curves (reference values) for V→F are valid for the fully opened (released) valve

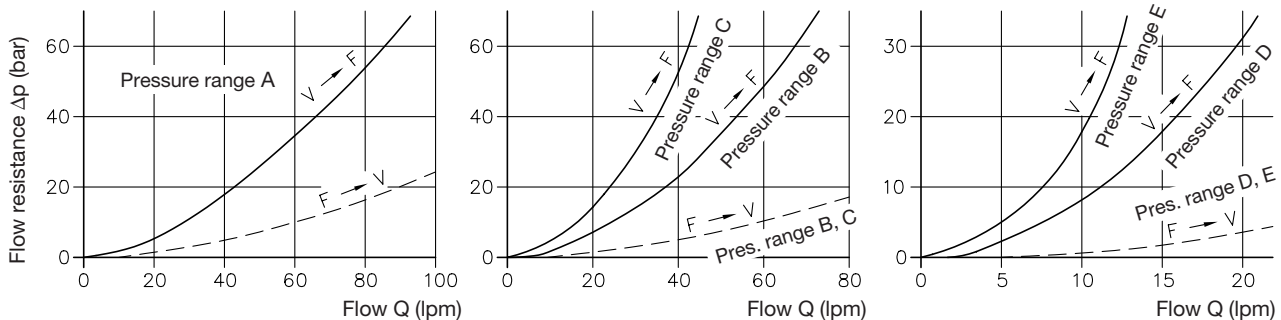

#### Functional restrictions

The double valves, flow pattern symbol 21... and 25..., cannot be utilized with directional valves, which show the flow characteristics of a differential circuit in one position, e.g. coding C in pamphlet D 5700. Single valves, flow pattern symbols 11 or 15, must not be connected to the rod side of hydraulic cylinders.

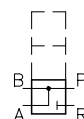

## 4. Dimensions All dimensions in mm and subject to change without further notice!

For the accessibility of the adjustable damping devices, see functional description B 7770.

### Type LHDV 33 P-11

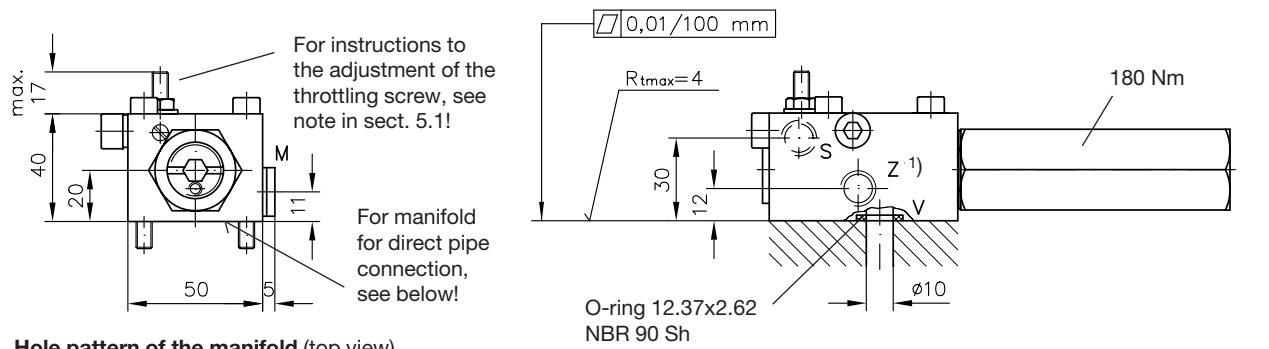

#### Hole pattern of the manifold (top view)

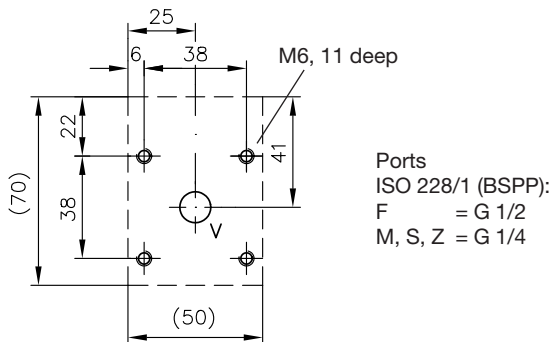

### Type LHDV 33 P-15

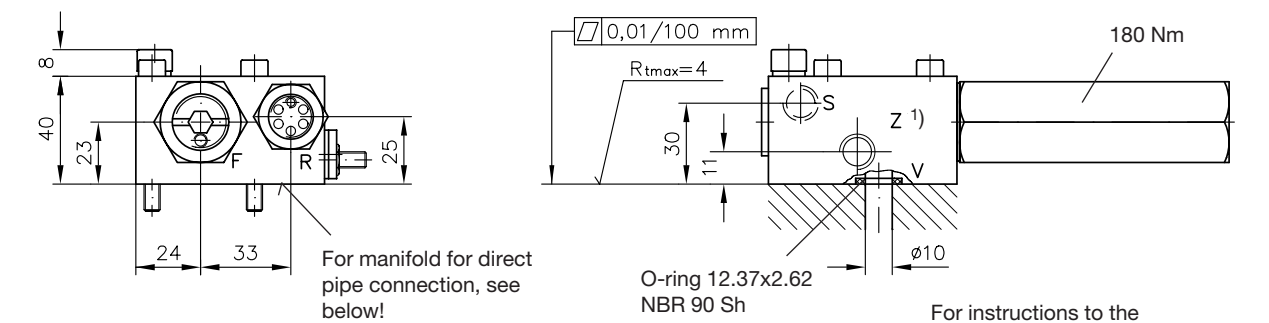

#### Hole pattern of the manifold (top view)

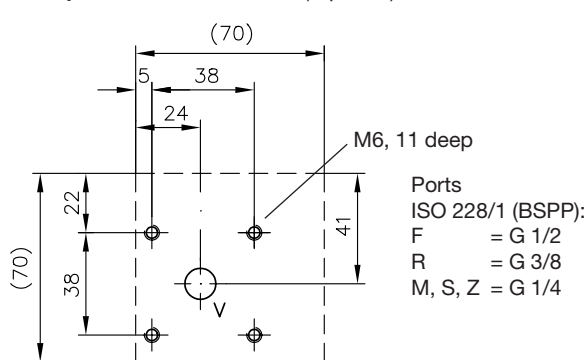

#### Connection block No. 7770 024

intended for direct pipe connection at port V (consumer side). Tapped port G 1/2 ISO 228/1 (BSPP). Suited for type LHDV 33 P-11. LHDV 33 P-15 To be ordered individually, when required.

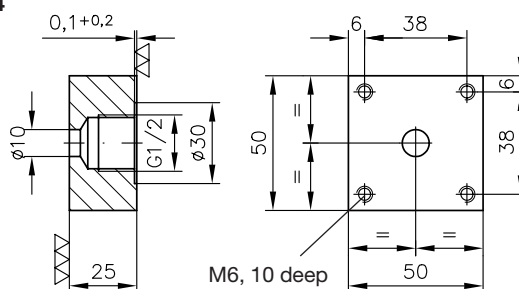

1) Port Z is not plugged ex-works. If it is not required, it may be blocked with a tapped plug e.g. DIN 908-G 1/4 A-St plus sealing ring DIN 7603-Cu-14x18x1.5.

2) **Attention:** The hexagon housing must be fixed while tightening the pipe fitting!

**Type LHDV 33 H-11**  
**LHDV 33 H-15**

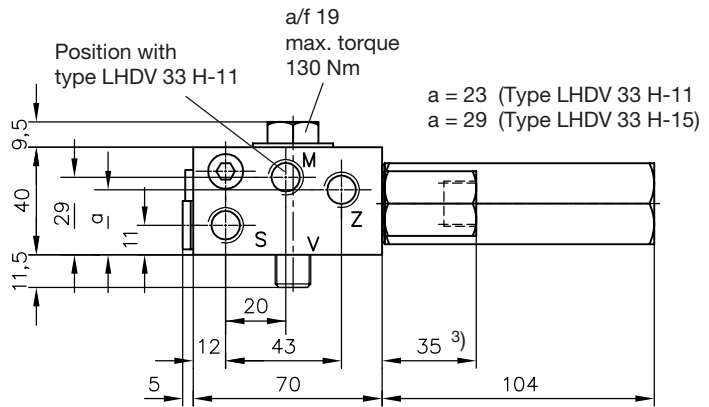
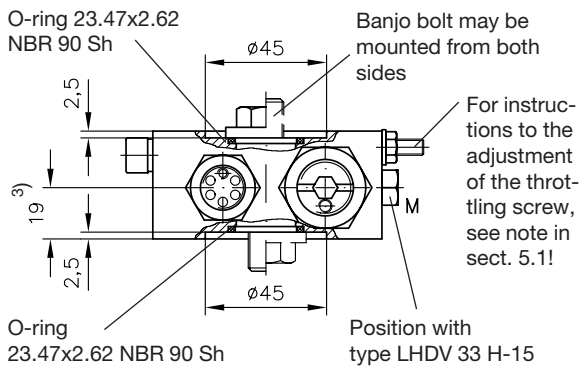

**Centering pedestal and mounting**

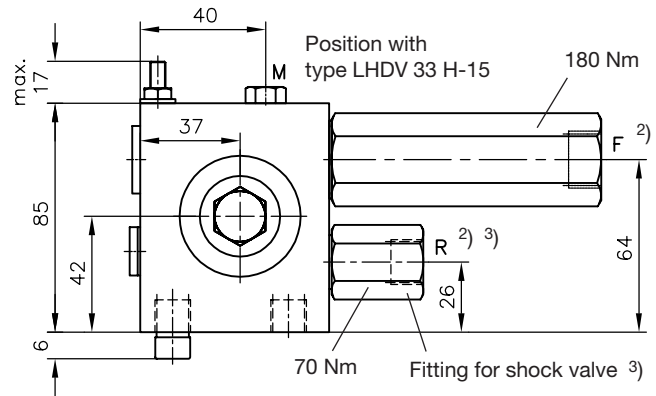
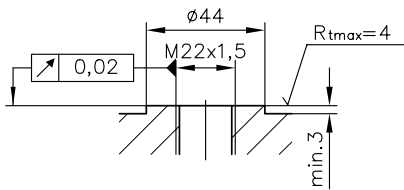

Ports	Thread
V with version ..H	M22x1.5 DIN 13
with version H 1/2	G 1/2 A ISO 228/1 (BSPP)
F	G 1/2 ISO 228/1 (BSPP)
R	G 3/8 ISO 228/1 (BSPP)
S, Z	G 1/4 ISO 228/1 (BSPP)
M	M8x1 DIN 13 (Type LHDV 33 H-15)
M	G 1/4 ISO 228/1 (BSPP) (Type LHDV 33 H-11)

**Type LHDV 33-21**  
**LHDV 33-21L**  
**LHDV 33-21W**  
**LHDV 33-21WD**  
**LHDV 33-21WL**

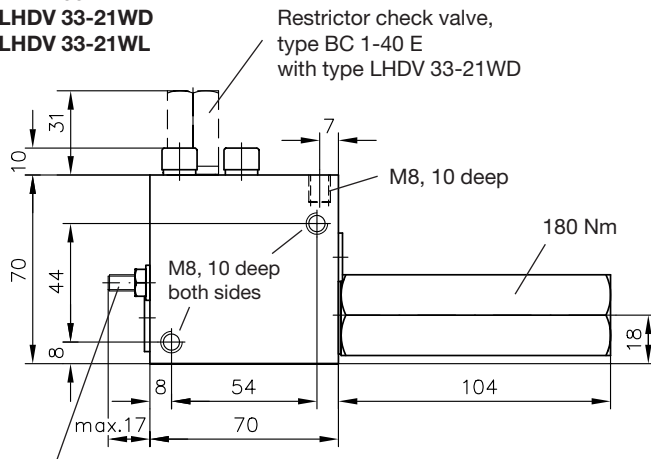

For instructions to the adjustment of the throttling screw, see note in sect. 5.1!

Port X with ... 21 W (WL) (type LHDV 33-21WD with additional hexagon housing)

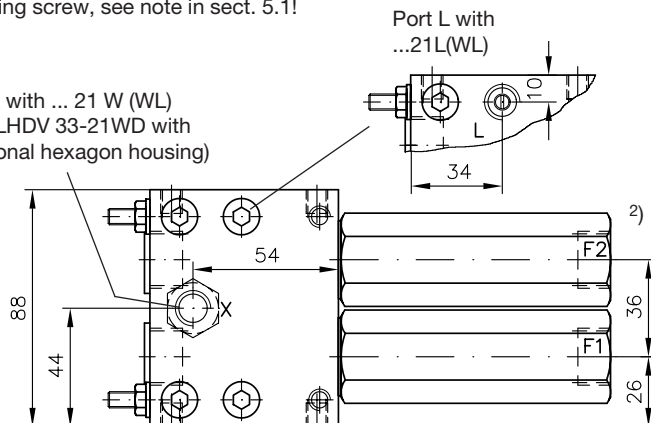

Ports conform. ISO 228/1 (BSPP):  
F1, F2, V1, V2 = G 1/2  
L, X = G 1/4

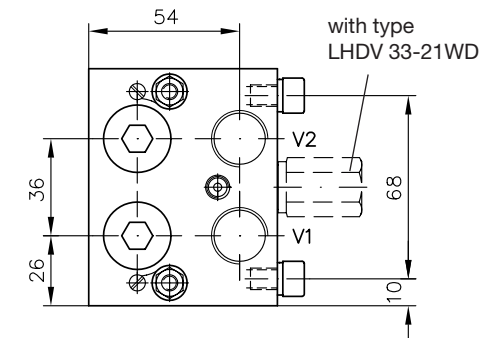

- 1) Port Z is not plugged ex-works. If it is not required, it may be blocked with a tapped plug e.g. DIN 908-G 1/4 A-St plus sealing ring 14x18x1.5 DIN 7603-Cu
- 2) **Attention:** The hexagon housing must be fixed while tightening the pipe fitting!
- 3) Fitting for shock valve and corresponding hole are not apparent with type LHDV 33 H-11

**Type LHDV 33-25**  
**LHDV 33-25L**  
**LHDV 33-25W**  
**LHDV 33-25WL**

For instructions to the adjustment of the throttling screw, see note in sect.5.1!

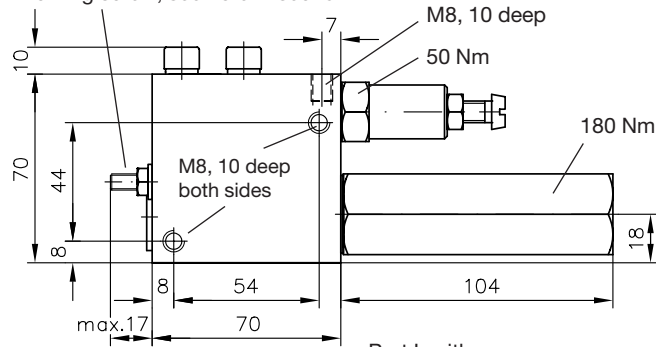

Ports ISO 228/1 (BSPP):  
 F1, F2, V1, V2 = G 1/2  
 L, X = G 1/4

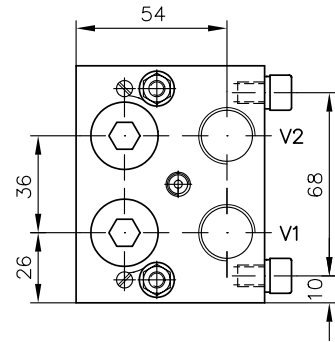
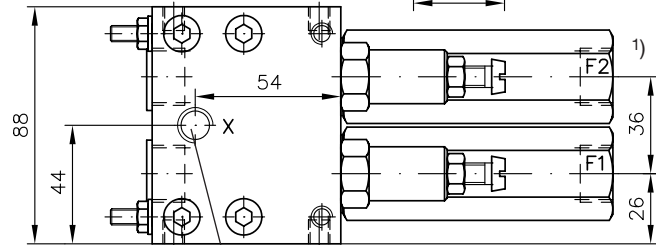
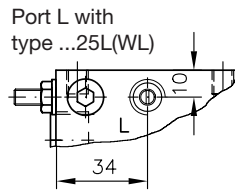

Port X with type ...25W(WL)

**Type LHDV 33-25WD**  
**LHDV 33-25WDL**  
**LHDV 33-25WDN**  
**LHDV 33-25WDNL**

Restrictor check valve, type BC 1-40 E with type LHDV 33-25WD(N)-...

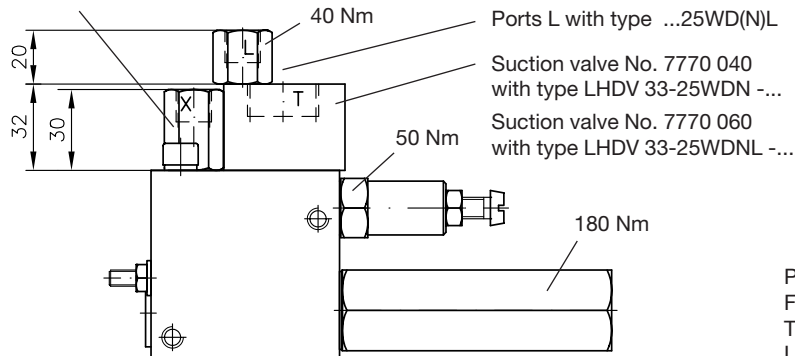

1) **Attention:**  
 The hexagon housing must be fixed while tightening the pipe fitting!

Ports conforming ISO 228/1 (BSPP):  
 F1, F2, V1, V2 = G 1/2  
 T = G 3/4  
 L, X = G 1/4

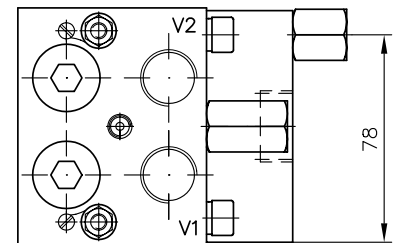
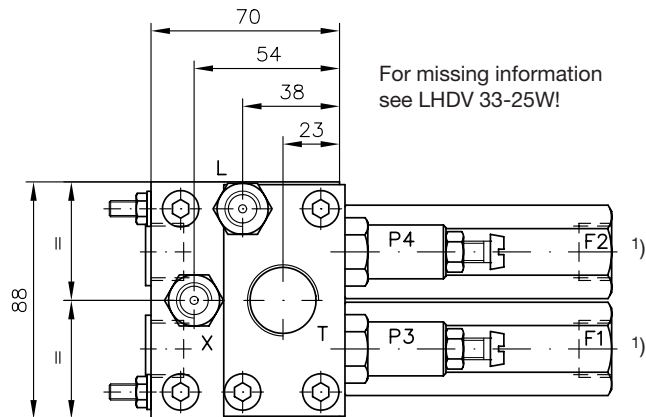

## 5. Appendix

### 5.1 Dampening throttles

The dampening behavior may be extensively adapted within the adjusting range. This can be performed on site. It is recommended to include the following note and the schematic drawing into the operating manual or the operating instructions of the equipment.

**The lock nut a/f 10 (Seal-Lock nut)** needs to be loosened sufficiently prior to adjusting the throttling screw, otherwise the vulcanized sealing gasket of the thread will be damaged!

#### Throttle screw

(grub screw ISO 4026 M6<sup>4h</sup> x 30-8.8-A2K)

**Attention:** Do not unscrew the throttle screw above the  $S_{max}$  (as is illustrated in the adjacent figure)! Due to construction restrictions it cannot be anchored on the inside of the equipment.

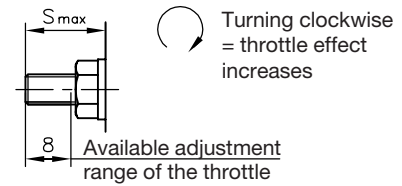
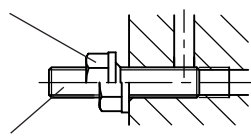

Version	$S_{max}$
Single valve	17 mm
Double valve	19 mm

### 5.2 Release pressure $p_{in}$ on the inflow side

The required pressure at the pump  $p_{in}$  to transfer the load against the load holding valve located down stream (direction  $V \rightarrow F$ ) can't be exactly predicted. It depends on the following parameter: Piston cross section area ratio  $A_{in} : A_{out}$  of the hydraulic cylinder, the internal operation area ratio of the load holding valve (release ratio acc. to sect. 3), the existing load pressure and the flow resistance  $\Delta p_{F(R)}$  of all additional throttling locations downstream back to the tank e.g. reflow pipe, directional valves (in the example  $A \rightarrow R$ ).

The setting of an additional shock valve installed in the feeding pipe of the consumer has to be adjusted high enough, over the setting of the main pressure relieve valve, that it can overcome the highest release pressure (no load situation).

Rough guiding figures suitable for a max. set pressure of 370 or 250 bar and max. flow dep. on valve coding, see sect. 2:

$p_{in \text{ max.}} \approx 130 \dots 170$  bar at 370 bar set pressure

$\approx 100 \dots 140$  bar at 250 bar set pressure

with a piston cross section area ratio  $A_{in} : A_{out}$  of about  $2 \dots 0.5$  for the hydraulic cylinder. The return flow resistance can increase these standard guiding figures by about  $(1.1 \dots 3.5) \times \Delta p_{F(R)}$  depending on the release ratio.

A readjustment of the pressure limiting valve is possible on site when required.

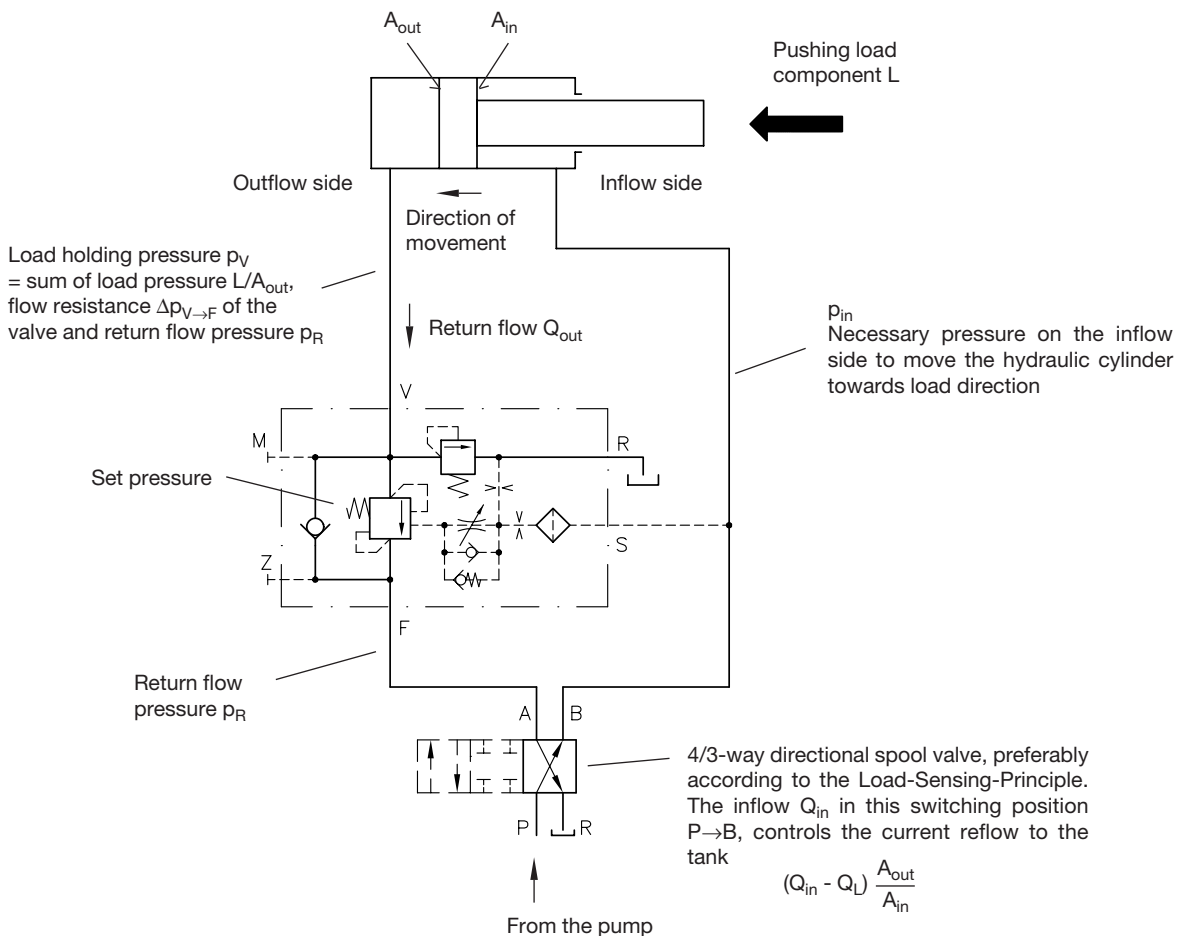

#### Important note:

The additional leakage port of the double valves acc. to sect. 2, page 3 (e.g. LHDV 33-21L ...) reduces the influence of the return flow resistance back to the tank. An additional advantage is in the possibility that this leakage pipe, in the case of an emergency, can be shut-off with a hand pump.