

Over-center valves type LHT

with oscillation damping

Flow rate Q_{max} = 250 lpm
Operation pressure p_{max} = 450 bar

See also:

- Over-center valve type LHK acc. to D 7100
- Over-center valve type LHDV acc. to D 7770



Version for screwing-in



Version for direct pipe connection



Version for manifold mounting



Banjo bolt version

1. General information

These over-center valves are throttle valves which are commonly used for a well controlled movement of loads connected to double acting hydraulic consumers (lifting and swivel cylinders). They prevent a collapse or eventual rupture of the fluid column. The velocity is determined by the flow to the consumer.

With dragging loads the flow out of the consumer is throttled in such a way that the pump, feeding the contrary side, always has to overcome a slight back pressure.

This back pressure is caused by a spring which usually is set about 15% higher than the respective maximum load induced pressure for the device enabling compensation of dynamic forces.

These valves can be customized to suit most applications by employing orifices of various diameter at the in- and outflow of the control line that influence the release ratio as well as the dampening characteristic. Special dampening elements like with type LHDV (D 7770) are only used at type LHTZ. Their use is most advantageous at applications where the dampening characteristic of type LHK (D 7100) is not sufficient, i.e. applications, which are less prone to low frequent oscillations like nodding etc.

The valve is zero leakage in unoperated state. All of these valves, beside valves with geometric release ratio $1 : \infty$, perform also as a safety valve. At valves with release ratio $1 : \infty$ (line rupture safety valves), the control pressure is independent of the load pressure. Therefore a shock valve installed as option in the valve body is necessary to safe guard eventual pressure surges or creeping pressure rise on the consumer side.

When the load is dropped via pressure at the opposing side this pressure will also enter the control line and open-up the outflow side i.e. only the design related back pressure valve will be effective.

● Design versions:

- Pipe connection (tapped ports or SAE-flange)
- for manifold mounting
- as banjo bolt
- for screwing-in

● Versions:

- double acting cylinders with control line (coding 11)
- double acting cylinders, ports of the opposite side in the block, minimized piping effort (coding 14)
- with additional shock valve enabling quick removal of pressure peaks (coding 15)
- with additional port enabling connection of a second, double acting consumer being operated in parallel (making a second over-center valve superfluous; coding 18)
- Circuitry for winches with integrated loose rope prevention (coding 17)
- Circuitry for double acting cylinders and alternating load directions (coding 21, 23, 25)

2. Available versions, main data

Order examples:

LHT 50 G -15-8- A 6-300/280

Individual valve for pipe connection

LHT 50 SAE -11-6- C 6-80

Individual valve with SAE connection flange

LHT 3 E B 7-400

Cartridge valve

LHT 21 H -14 B 4-350

Version for banjo bolt mounting

LHT 33 OMP -21 A 7-250 -B 7-250

Double valve for sub-plate mounting

Outflow orifice D2 see table 2, page 3

Shock pressure (bar) (only at symbol -15, -23, -25)

Load pressure (bar) (or release pressure with $\psi_{geo} = 1 : \infty$)

Pressure ranges shock valves:

Basic type	Pressure range (bar)
LHT 23 SAE-25W	90 ... 160 161 ... 220 221 ... 340
LHT 33 P-15 LHTZ 33 P-15 LHTZ 30 P-23	20 ... 160 161 ... 400
LHT 34 G-15	150 ... 250 251 ... 340
LHT 50 ...-15	20 ... 160 161 ... 450

Table 1:

Basic type, size, connection manner and symbols	Flow coding						Geometric release ratio ψ_{geo}	
	A	B	C	D	E	F		
Size 2	28	14	10	6	3	--	4 1 : 4	
LHT 21 G -11 LHT 21 P -11 LHT 21 P -14 LHT 21 UNF P -14 LHT 21 H -14 LHT 22 G -11 LHT 22 P -11 LHT 23 SAE -25W	Flow rating (lpm) with $\Delta p_{V \rightarrow F}$ of approx. 40 bar Also avail. coding AB , flow rating = 20 lpm (see Δp -Q-curve in sect. 3)						8 1 : 8	Pressure range (bar) ¹⁾ 20 ... 60 61 ... 250 251 ... 400
Size 3	130	85	55	35	20	10	7 1 : 7	0 1 : ∞ ²⁾
LHT 33 G -11 LHT 33 P -11 LHT 33 P -15 LHT 33 OMT -17E LHT 33 SAE -18 ³⁾ LHT 33 OMP -21 LHT 34 G -15 LHTZ 30 P -23 LHTZ 33 P -15	Flow rating (lpm) with $\Delta p_{V \rightarrow F}$ of approx. 40 bar						Pressure range (bar) ¹⁾ 20 ... 49 50 ... 199 200 ... 319(400) ³⁾ from 320	Release pressure D2 = 0 D2 = 6 9 ... 14 24 ... 43 15 ... 25 46 ... 123 26 ... 40 250 ... 310 41 ... 65 66 ... 90
LHT 3 E ¹⁾	130	85	55	35	20	10	4 1 : 4 7 1 : 7	
	130	85	55	--	--	--	10 1 : 10	Pressure range (bar) ¹⁾ 20 ... 200 201 ... 400
Size 5	250	200	150	100	50	25	6 1 : 6	0 1 : ∞ ²⁾
LHT 50 G -11 LHT 50 SAE -11 ³⁾ LHT 50 SAE -14 ³⁾ LHT 50 G -15 LHT 50 SAE -15 ³⁾	Flow rating (lpm) with $\Delta p_{V \rightarrow F}$ of approx. 40 bar						Pressure range (bar) 20 ... 89 90 ... 259 260 ... 450(400) ³⁾	Release pressure D2 = 0 D2 = 6 15 ... 30 46 ... 90 31 ... 70 95 ... 215 71 ... 100 216 ... 305

Symbol

Connection manner:

- E = Cartridge valve (The inflow and the optional outflow orifice must be integrated somewhere else in the manifold!)
- H = With banjo bolt
- G = For pipe connection conf. ISO 228/1 (BSPP)
- P = For manifold mounting (only port V is housed in the manifold)
- SAE = For SAE connection flange
- OMT = For direct mounting onto motors type OMT (Co. DANFOSS)
- OMP = For direct mounting onto motors type OMP or OMR (Co. DANFOSS)

Geometric release ratio $\psi_{geo} \neq 1 : \infty$

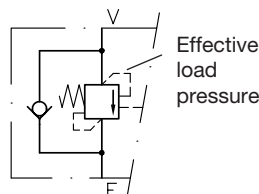

Geometric release ratio $\psi_{geo} = 1 : \infty$ ²⁾

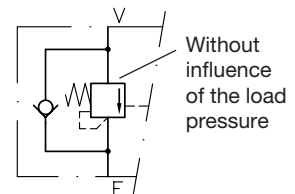

Footnotes 1) 2) 3) see page 3!

Symbols

Basic valve (illustrated for geom. release ratio $\psi_{geo} \neq 1 : \infty$)

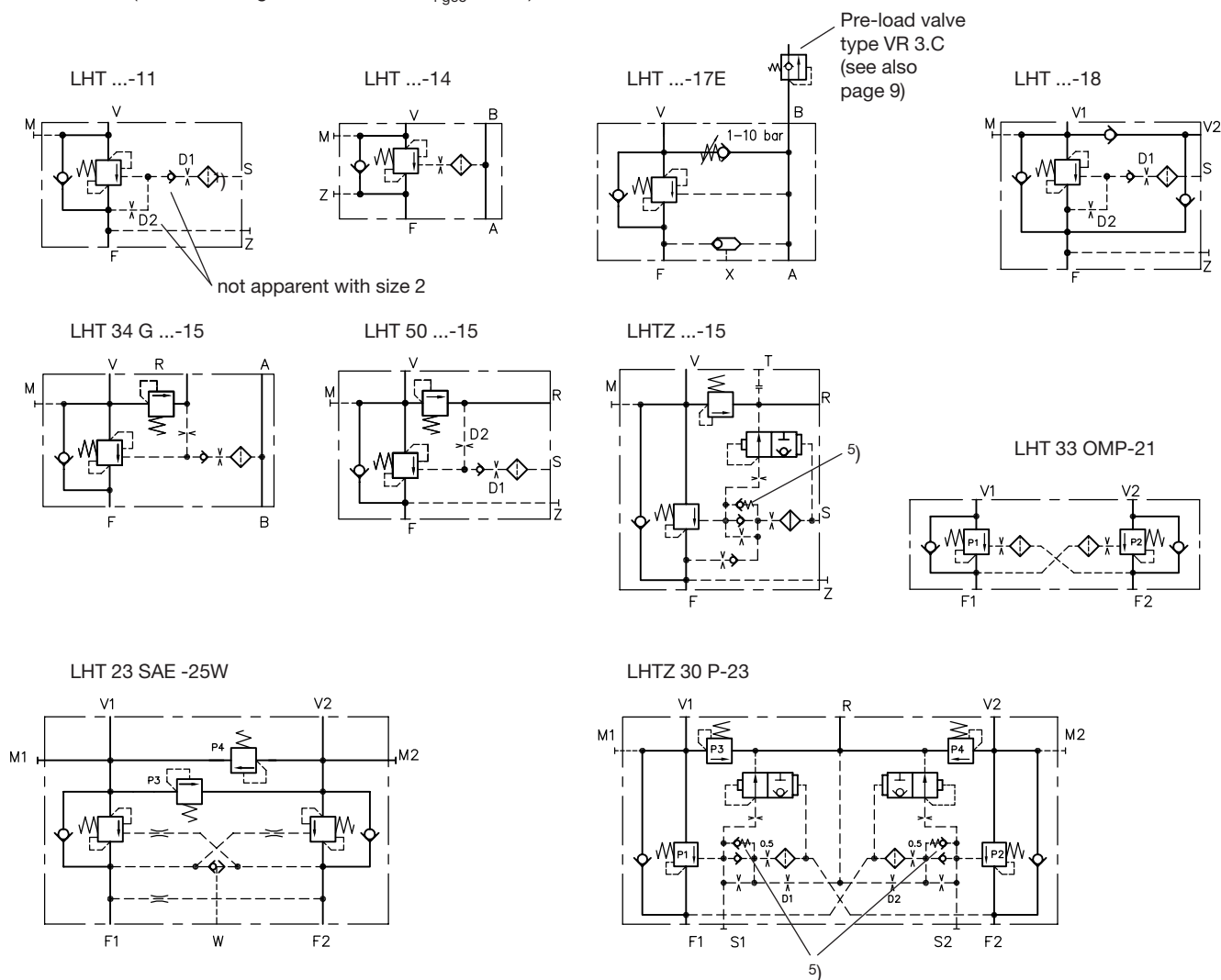
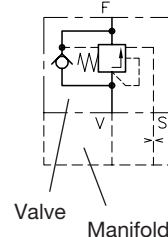

Table 2: Effective release ratio ψ_{real} , outflow orifice D2
 Type LHT 2..., LHT 33 OMT(OMP) and LHT 3 E only with geom. release ratio ψ_{geo}
 (no outflow orifice D2); With all other versions the effective release ratio ψ_{real} i.e. the necessary
 release pressure is determined by the orifice combination D1/D2

Examples: LHT 33 P11 - 6 - A7 - 200 A release pressure p_{contr} of approx. 90 bar is necessary
 $\psi_{geo} = 1 : 7$, $\psi_{real} = 1 : 2.28$ (without effective load pressure)

LHT 33 P11 - 0 - A7 - 200 A release pressure p_{contr} of approx. 30 bar is necessary
 $\psi_{geo} = \psi_{real} = 1 : 7$

Cartridge valve
 LHT 3E



Coding	4	5	6 (series)	7	8	0 ⁴⁾	
Orifice-Ø (mm)	0.4	0.5	0.6	0.7	0.8	--	
Actual (dynamic) release ratio with type	LHT 3...-4-...	1 : 2.84	1 : 2	1 : 1.30	1 : 0.83	1 : 0.53	1 : 4
	LHT 3...-7-...	1 : 4.96	1 : 3.5	1 : 2.28	1 : 1.45	1 : 0.93	1 : 7
	LHT 5...-6-...	1 : 4.26	1 : 3	1 : 1.95	1 : 1.24	1 : 0.79	1 : 6

Note: Inflow orifice D1 Ø0.5 mm (standard, no coding).

- 1) Type LHT 2..., LHT 33 OMT(OMP) and LHT 3E only with geom. release ratio ψ_{geo} (no outflow orifice D2)
- 2) Notes regarding geom. release ratio $\psi_{geo} = 1 : \infty$
 - This valve version does not show a safety valve function, as the load pressure is not applied (see symbol)
 - The set release pressure p_{contr} directly corresponds to the necessary pressure at port S to open the valve.
 - The functionality is like with a line rupture safety valve.
 - **Attention:** The use of an outflow orifice D2 (acc. to table 2) will dampen oscillations but will raise the required pressure at port S (see the various pressure ranges at table 1)
- 3) p_{max} is restricted for version with SAE hole pattern
- 4) Prepared, the outflow port of the control line is plugged, corresponds to the geom. release ratio ψ_{geo}
- 5) Set at 30 bar by HAWE (adjustable range 10 ... 50 bar)

3. Additional parameters

Nomenclature	Over-center valve with hydraulic release and bypass check valve						
Design	Over-center valve: cone seated valve Bypass check valve: plate seated valve						
Installed position	Any						
Ports	F, V, V1, V2, A, B and R M, S and Z			Main ports Control and pick-up ports dep. on type			
Mass (weight) approx. kg	LHT 21 H -14 = 0.6	LHT 21(22) G(P) -11 = 0.8	LHT 21 (UNF)P -14 = 1.0	LHT 23 SAE -25W = 3.2	LHT 3 E = 0.6	LHT 33 G(P) -11 = 1.3 LHT(Z) 33 P -15 = 1.7 LHT 33 SAE -18 = 2.4 LHT 33 OMT -17E = 2.4 LHT 33 OMP -21 = 2.8 LHT 34 G -15 = 2.2 LHTZ 30 P -23 = 5.0	LHT 50 G -11 = 2.4 LHT 50 SAE -11 = 3.0 LHT 50 G -15 = 3.2 LHT 50 SAE -14(15) = 3.9

Flow direction	Operation direction (load holding function) V → F, V1 → F or V2 → F Free flow F → V, F → V1, F → V2
Release ratio	Blocked valve approx. 1 : 4, 1 : 7, 1 : 8, 1 : 6 dep. on basic type Opened (released) valve approx. 1 : 1 to 1 : 5 dep. on orifice-Ø-ratio and basic type see sect. 2
Pressure adjustment	A pressure gauge should be used whenever the pressure setting is adjusted or altered! The given figures for pressure alternation per rotation and per mm adjustment travel of the perforated disc (within the connector F) or of the set screw (at the spring housing) are only a rough guide line for approximately achieving the desired setting (start of operation). The setting should be at least 15% above the max. expected load pressure. Over-center valve function ($\psi_{geo} = 1 : 4; 1 : 8; 1 : 7; 1 : 6$) Line rupture safety valve function ($\psi_{geo} = 1 : \infty$)

Pressure alterations (over-center valve)	Type	ψ_{geo}	Pressure variation per mm according to pressure range Δp_{Spring} (bar/mm)			Pressure variation per turn Δp_{set} (bar/U) = k · Δp_{Spring}
			0 ... 60 bar	61 ... 250 bar	251 ... 400 bar	
LHT 2		1 : 4	24	41	124	k = 1.34 k = 1.25 (only LHT 21 (UNF) P 14)
		1 : 8	49	85	255	
			20 ... 42 bar	50 ... 199 bar	200 ... 318 bar	
LHT 3	1 : 7	18	30	40		
	1 : ∞	9 ... 14 bar	26 ... 40 bar	41 ... 65 bar		
LHT 3 E		---	0 ... 200 bar	201 ... 450 bar	k = 1.25	
		1 : 4	---	16		30
		1 : 7	---	30		40
LHT 5		1 : 6	20 ... 89 bar	90 ... 259 bar	260 ... 450 bar	k = 1.25
			14	27	29	
		1 : ∞	15 ... 30 bar	31 ... 70 bar	71 ... 100 bar	
			3	5	6	

Pressure alterations (shock valve)	Type	LHT 23..-25..			LHT 33 P-15..		LHT 34 G-15..		LHT 5..-15..	
Spring (pressure p_{max} bar)		340	220	160	400	160	340	250	450	160
Pressure alternation (bar/rev.)		--	--	--	100	19	--	--	80	17.5
Pressure alternation (bar/mm)		40	27	17	--	--	66	40	--	--

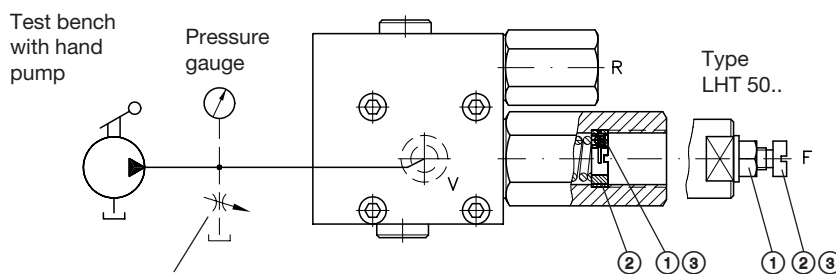

This bypass-throttle valve is a must with test rigs using a motor pump! The pump should be circulating via opened throttle valve, then close the throttle valve slowly until LHT starts barely responding (avoid larger flow since the valve might squeal).

Attention: The pump has to be connected to port S with geom. release ratio $\psi_{geo} = 1 : \infty$!

- ① Slacken the Both grub screw or SEAL-LOCK nut which serve for locking ② and must be slackened prior to any pressure adjustment
- ② The perforated disc can be rotated with an allen key a/f 6 (mm), the set screw with a screw driver
 = pressure increases
 = pressure decreases
- ③ Retighten the grub screw / SEAL-LOCK nut ① after performed adjustment.

Continuation: Additional parameters

Hydraulic fluid

Fluids acc. to DIN 51524 table 1 to 3; ISO VG 10 to 68 acc. to DIN 51519
 Viscosity range: min. approx. 4; max. approx. 1500 mm²/s
 Optimal operation range: approx. 10...500 mm²/s
 Also suitable are biologically degradable pressure fluids of the type HEPG (Polyalkylenglycol) and HEES (synth. Ester) at operation temperatures up to approx. +70°C.

Temperature

Ambient: approx. -40...+80°C
 Fluid: -25...+80°C, pay attention to the viscosity range!
 Start temperature down to -40°C are allowable (Pay attention to the viscosity range during start!), as long as the operation temperature during subsequent running is at least 20K higher.
 Biological degradable pressure fluids: Pay attention to manufacturer's information. With regard to the compatibility with sealing materials do not exceed +70°C.

Functional restriction

The use of these is restricted when combined with directional valves enabling differential circuitry during any switching position e.g. coding C of D 5700. Valves intended for one load direction only (symbols 11 to 18) must not be connected to the rod side of hydraulic cylinders.

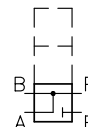

Δp -Q-curves

Operation direction V → F (depending on the flow size, acc. to table 1 in sect. 2)
 Free flow F → V (characteristic back pressure)

Type LHT 2..

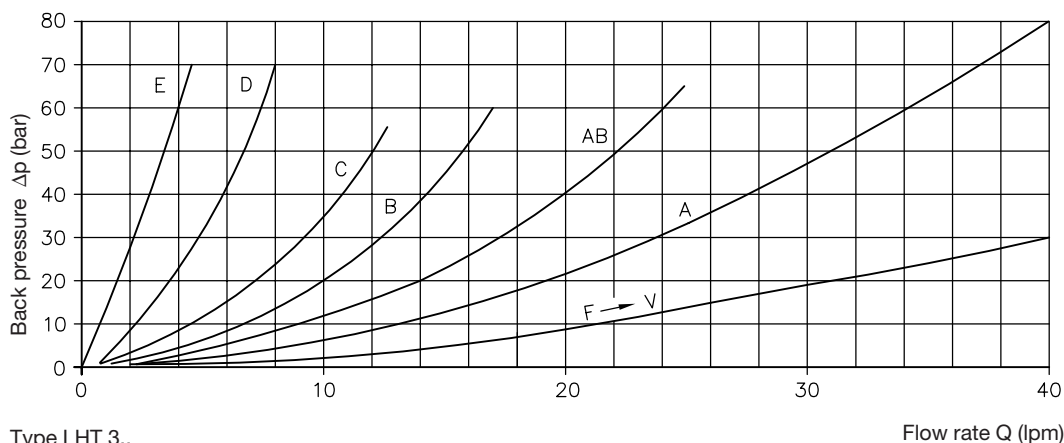

Type LHT 3..

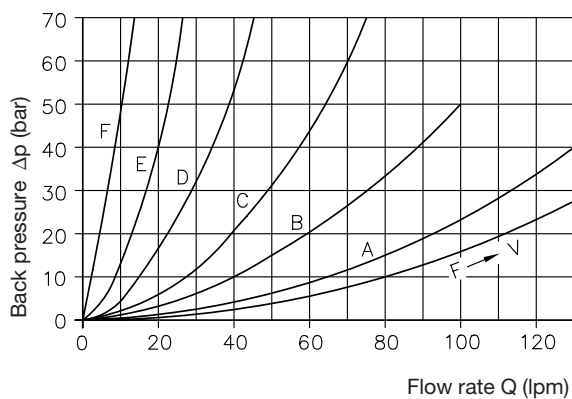

Type LHT 50..

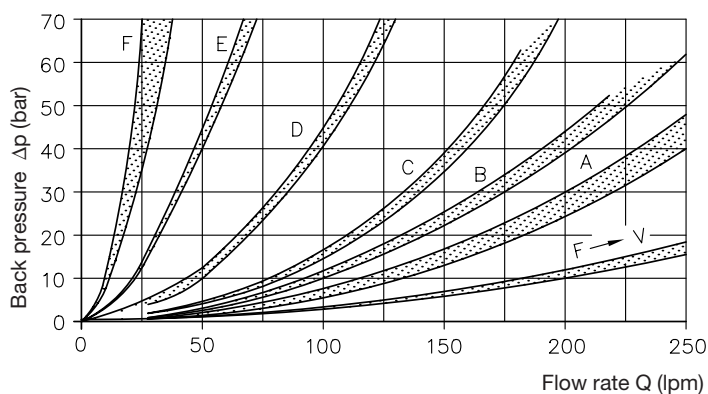

Fluid viscosity during tests approx. 50 mm²/s

4. Unit dimensions

All dimensions in mm, subject to change without notice!

4.1 Basic valves

Type LHT 21 G-11
LHT 22 G-11

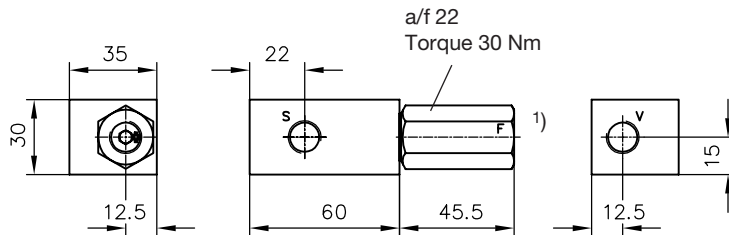

Ports conforming
ISO 228/1 (BSPP):
LHT 21 V, F = G 1/4; S = G 1/4
LHT 22 V, F = G 3/8; S = G 1/4

Type LHT 21 H-14

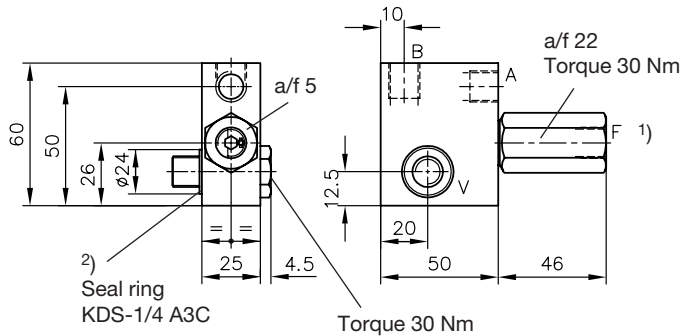

Ports conforming ISO 228/1 (BSPP):
A, B, F, V = G 1/4

2) Both, the seal ring and the spot
face show the same diameter.

Type LHT 21 P-11
LHT 22 P-11

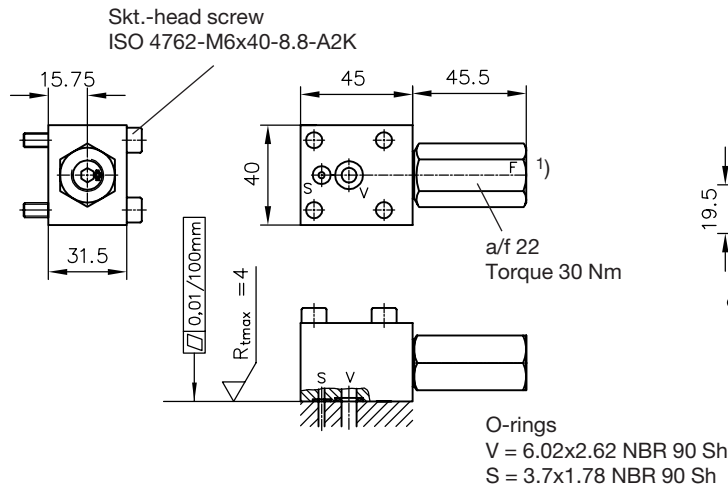

Hole pattern of the manifold
(top view)

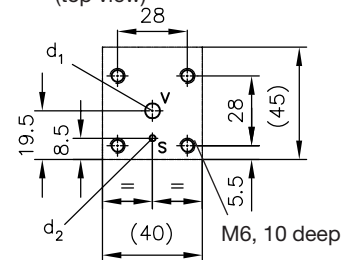

d₁ = max. $\phi 5$
d₂ = max. $\phi 3$

Type LHT 21 P-14
LHT 21 UNF P-14

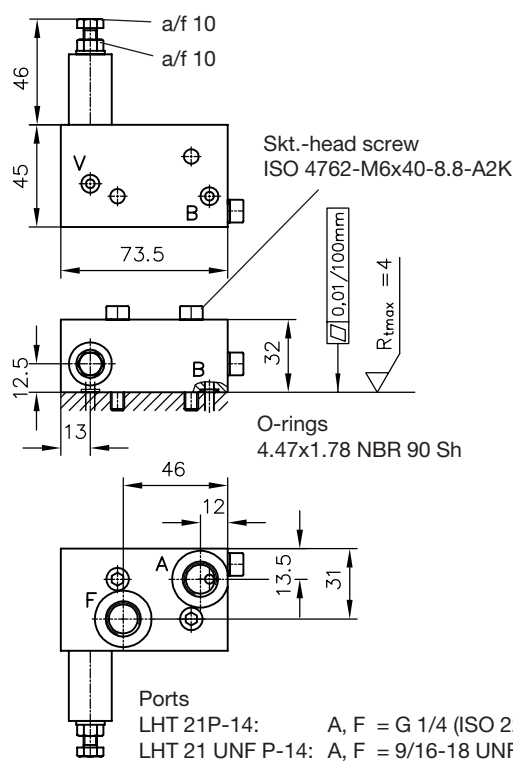

1) **Attention:**
The hexagonal spring housing must be
countered while installing the pipe fitting !

Hole pattern of the manifold
(top view)

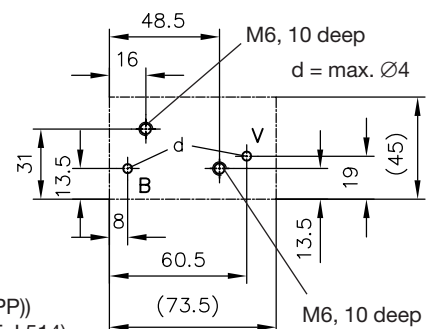

Type LHT 23 SAE-25W

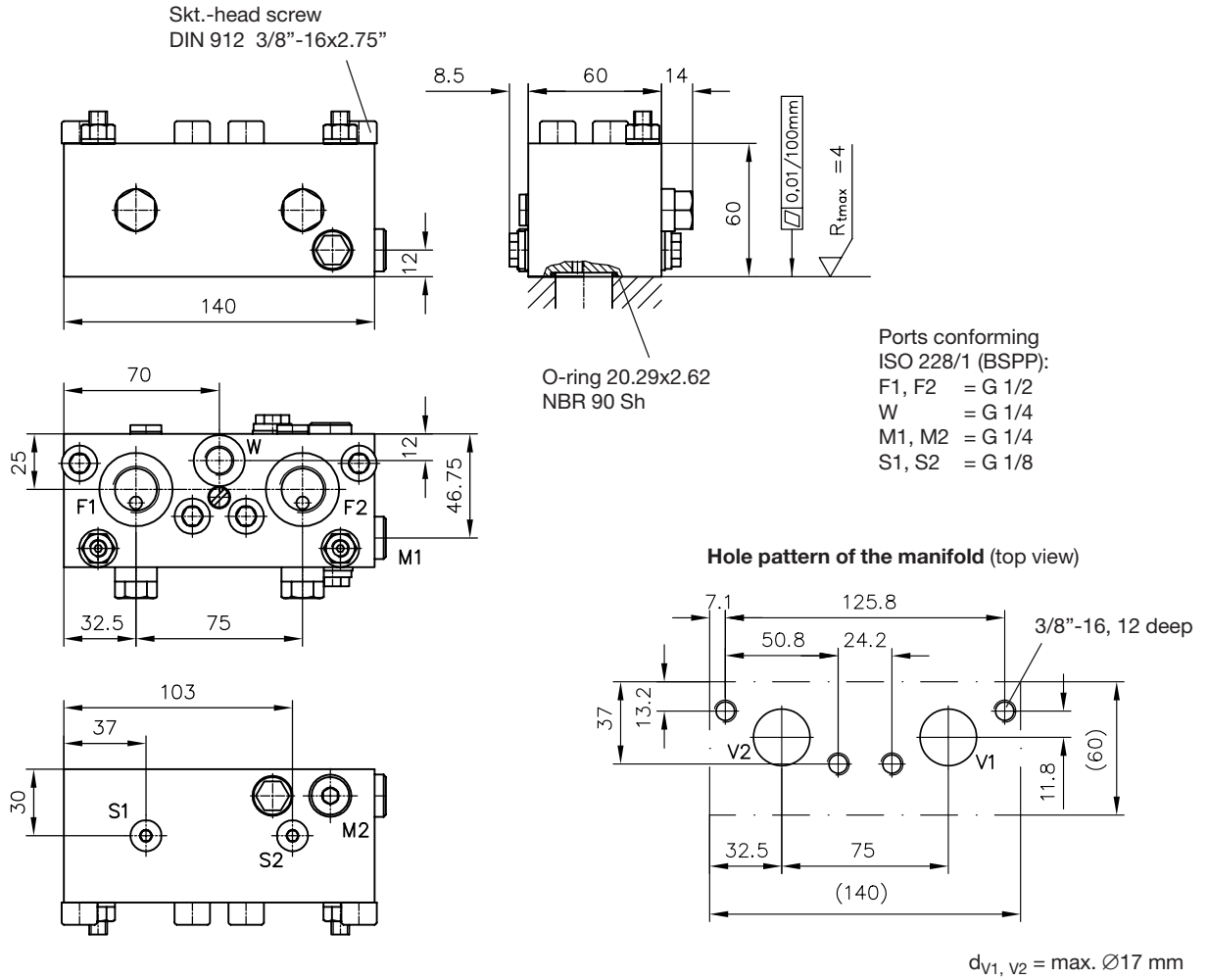

Type LHT 33 G-11

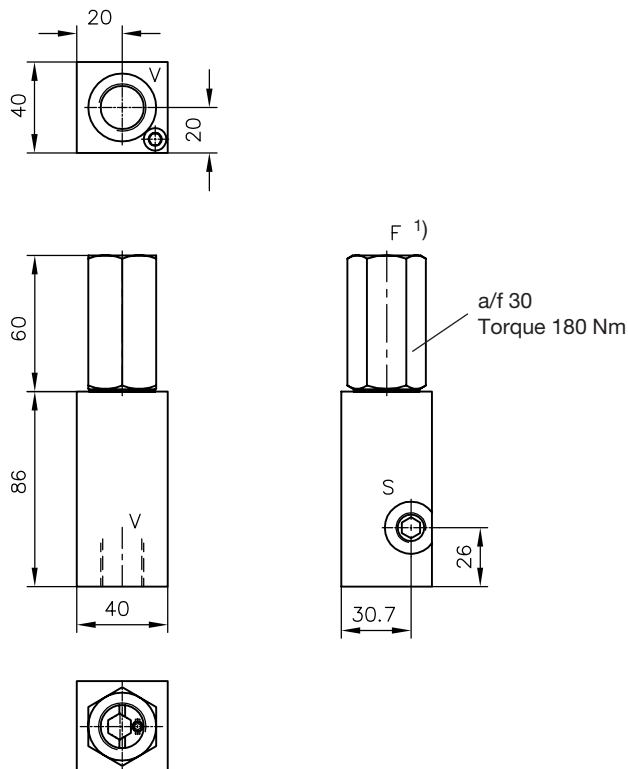

1) **Attention:**
The hexagonal spring housing must be countered while installing the pipe fitting!

Type LHT 33 P-11

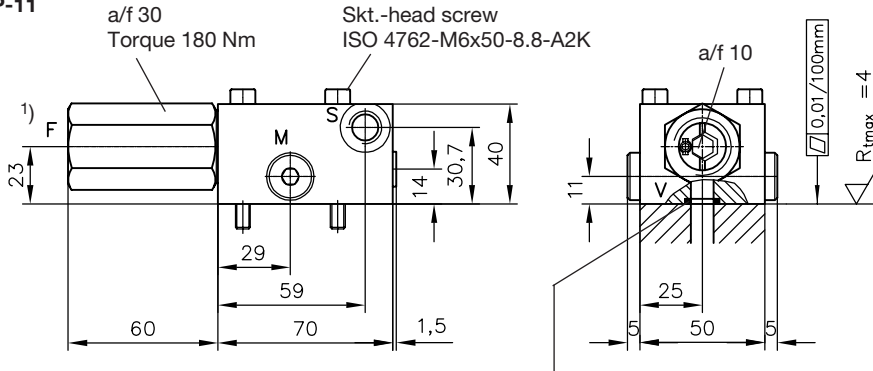

O-ring 12.37x2.62
NBR 90 Sh

Ports conforming
ISO 228/1 (BSPP):
F = G 1/2
M, S, Z = G 1/4

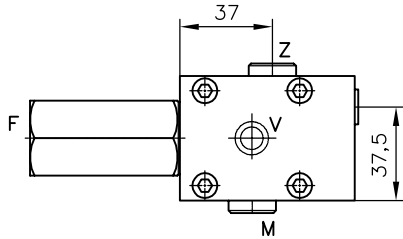

Hole pattern of the manifold (top view)

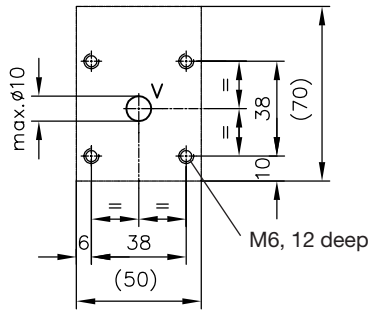

Type LHT 33 P-15

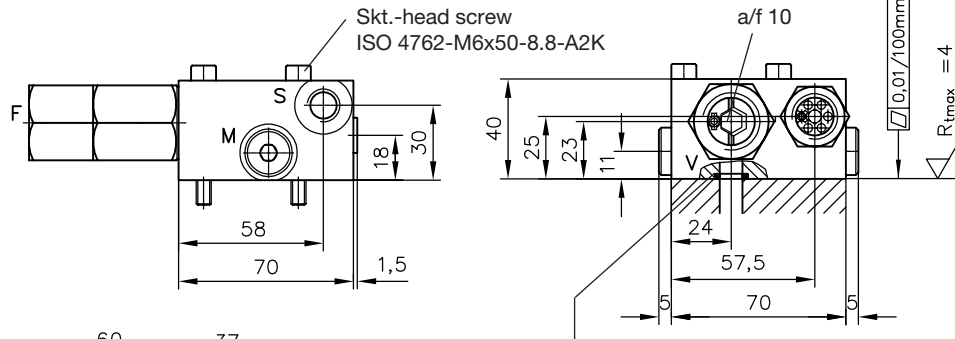

O-ring 12.37x2.62
NBR 90 Sh

Ports conforming ISO 228/1 (BSPP):
F = G 1/2
M, S, Z = G 1/4
R = G 3/8

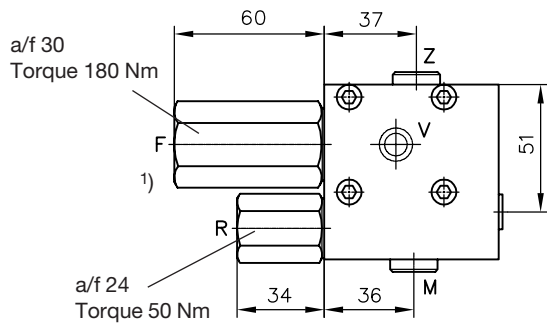

Hole pattern of the manifold (top view)

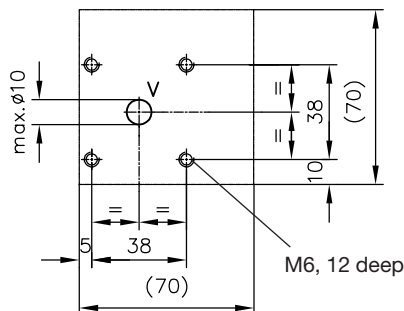

1) **Attention:**
The hexagonal spring housing must be
countered while installing the pipe fitting!

Type LHT 33 OMT-17E

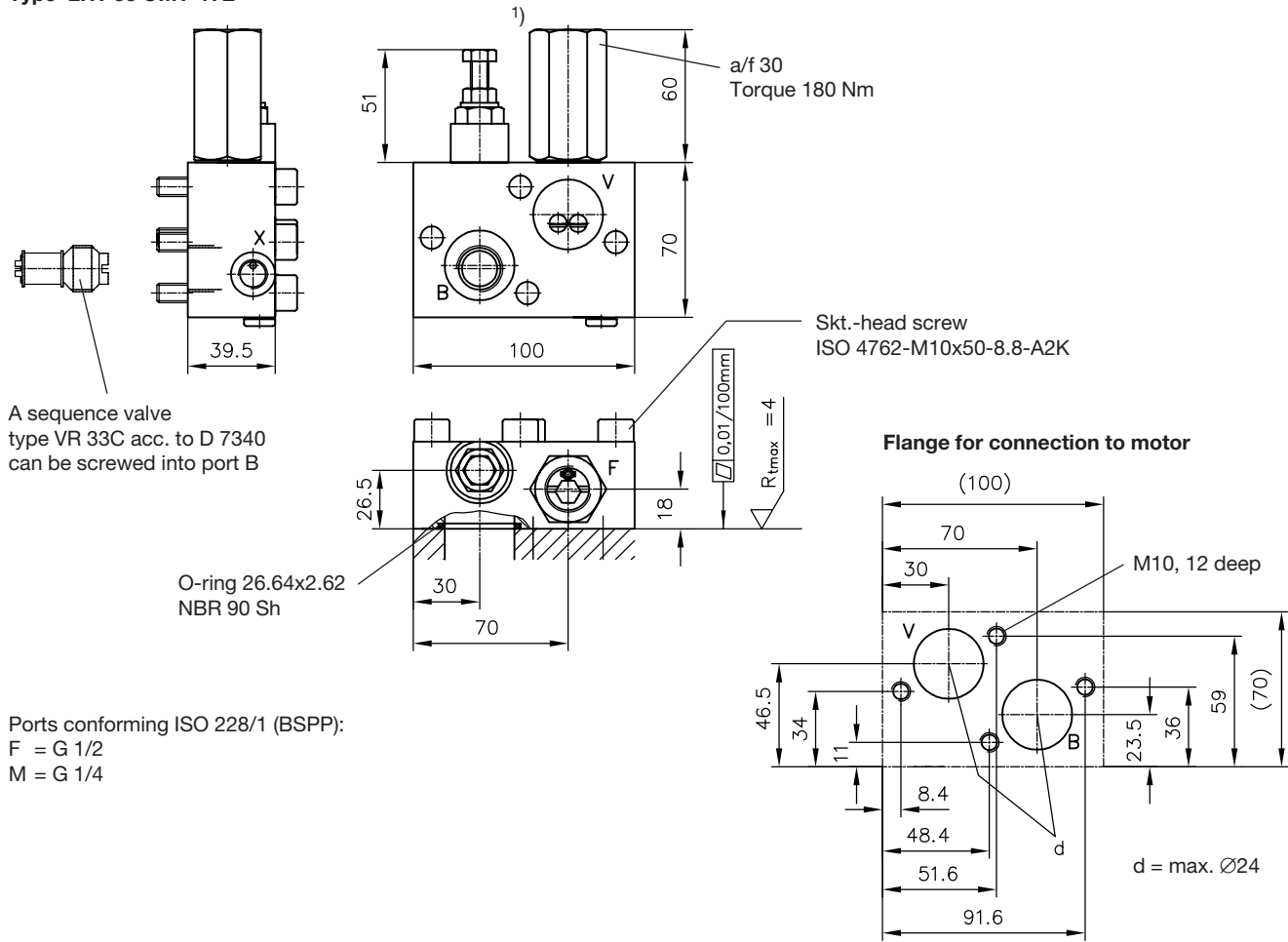

Type LHT 33 SAE-18

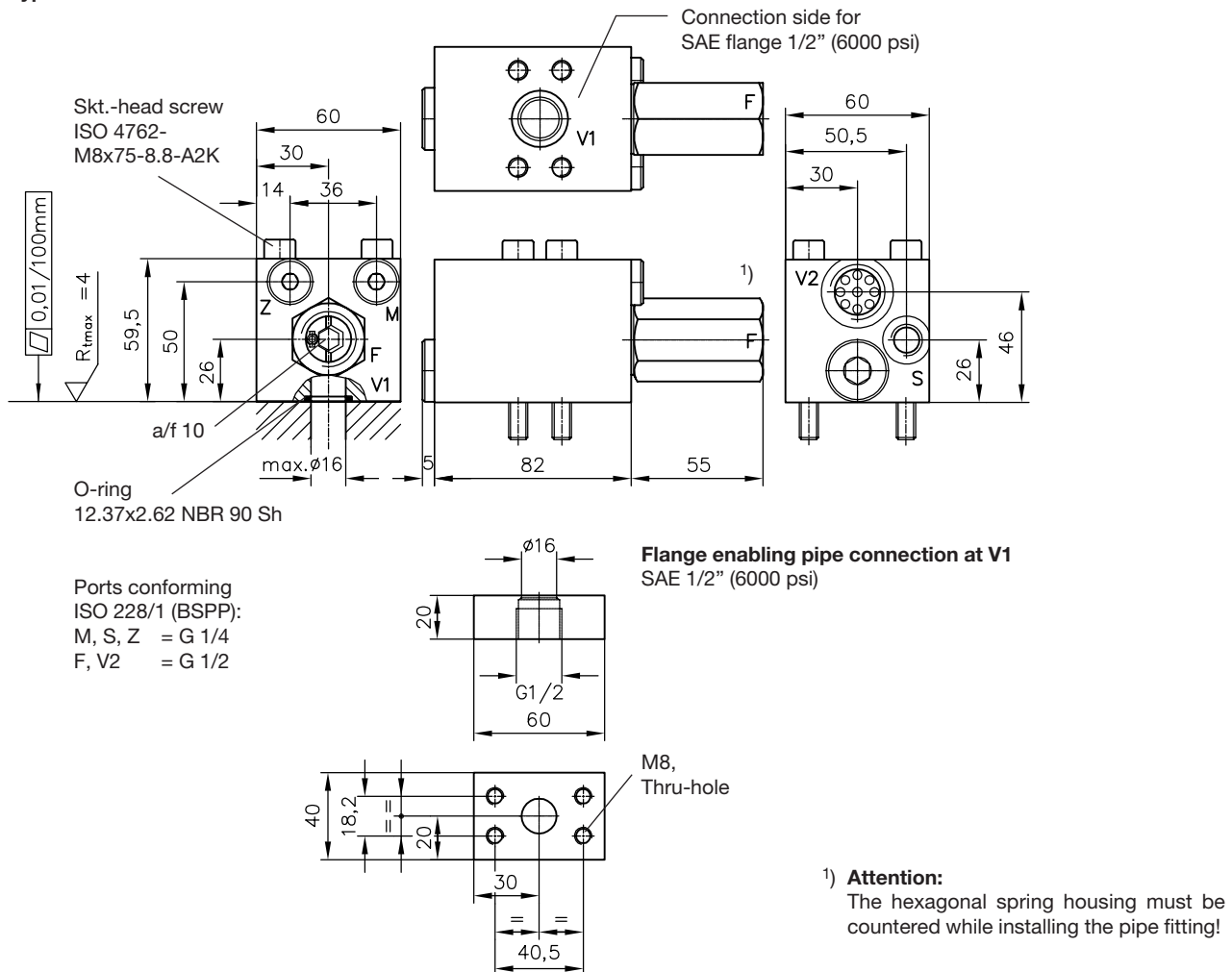

Type LHT 34 G-15

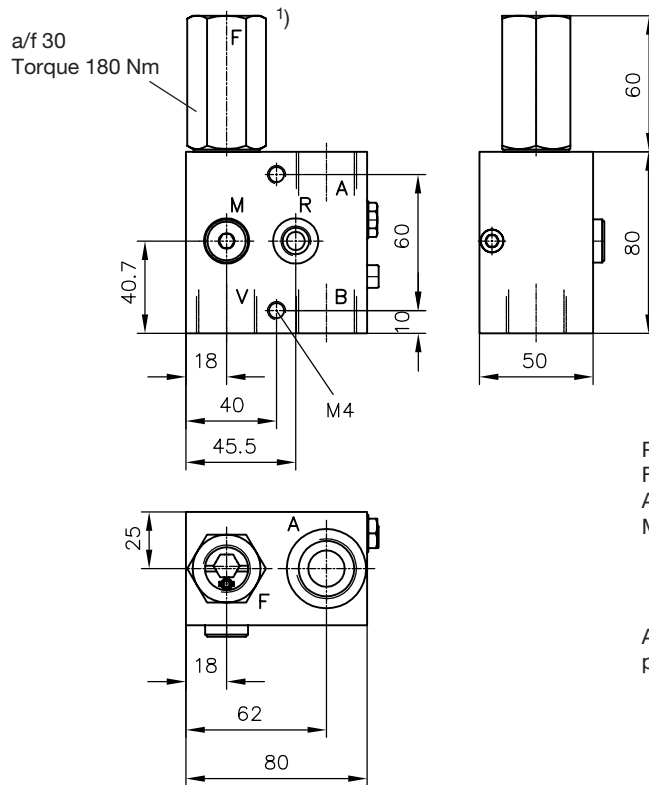

Ports conforming ISO 228/1 (BSPP):
 F, V = G 1/2
 A, B = G 3/4
 M, R = G 1/4

Adjustment of the shock valve only possible via washers (see sect. 3)

Type LHTZ 33 P-15

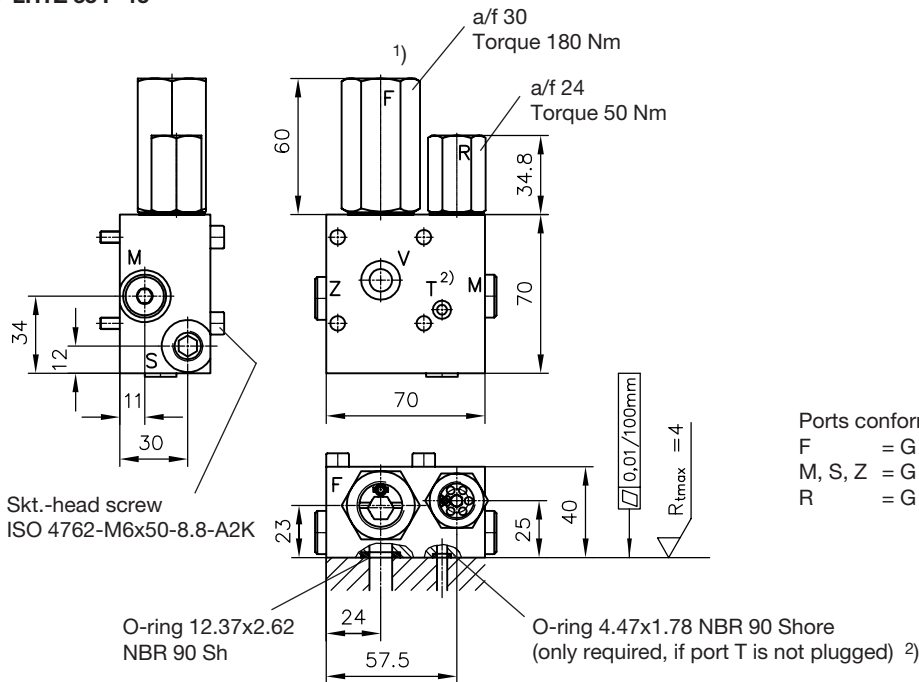

Ports conforming ISO 228/1 (BSPP):
 F = G 1/2
 M, S, Z = G 1/4
 R = G 3/8

Hole pattern of the manifold (top view)

$d_1 = \text{max. } \varnothing 10$
 $d_2 = \text{max. } \varnothing 4$

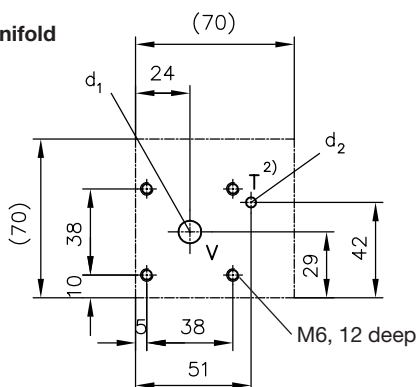

1) **Attention:**
 The hexagonal spring housing must be countered while installing the pipe fitting !

2) Port T is plugged with a grub screw ISO 4027-M4x5-45H and a ball 3 mm DIN 5401 with all standard versions.
 A sealing via O-ring is not required.

Type LHTZ 30 P-23

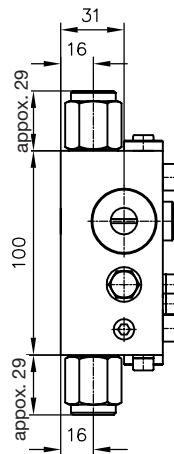
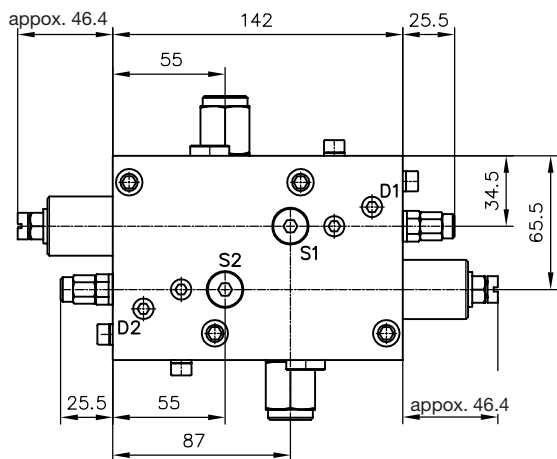
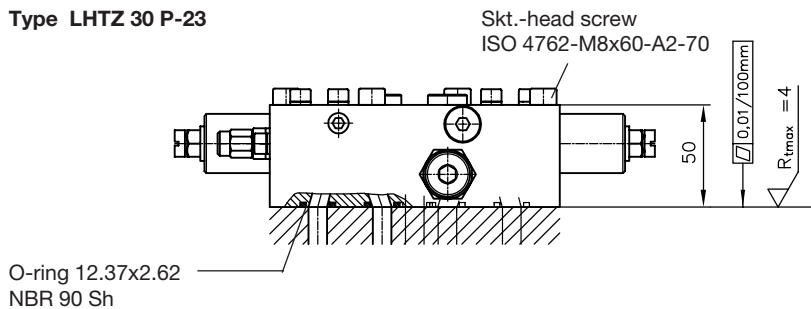

Ports conforming
ISO 228/1 (BSPP):
S1, S2 = G 1/4

Hole pattern of the manifold (top view)

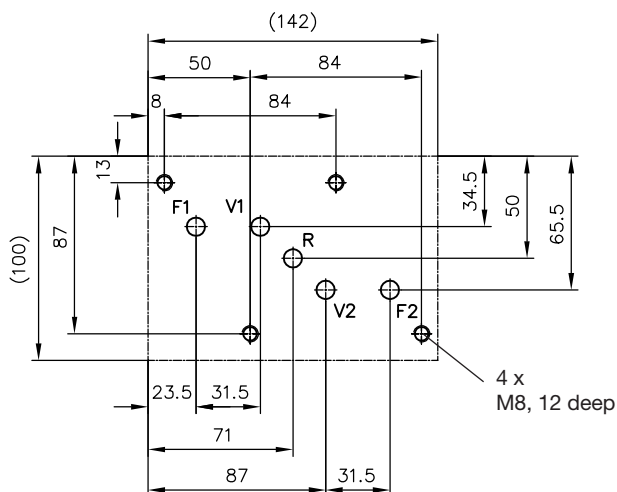

$d_{F1, F2, V1, V2, R} = \text{max. } \varnothing 10$

Type LHT 33 OMP-21...

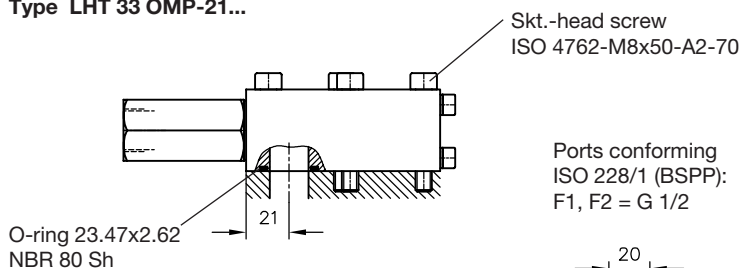

Ports conforming
ISO 228/1 (BSPP):
F1, F2 = G 1/2

a/f 30
Torque
180 Nm

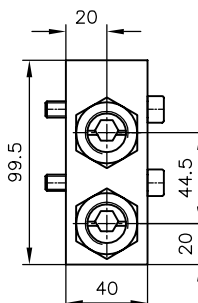
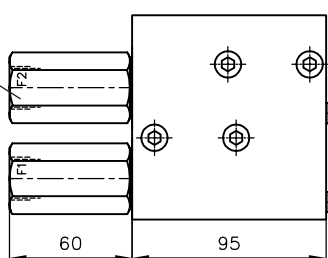

Hole pattern of the manifold (top view)

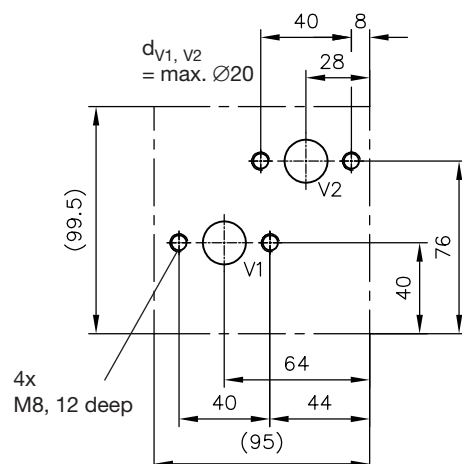

Type LHT 50 G-11

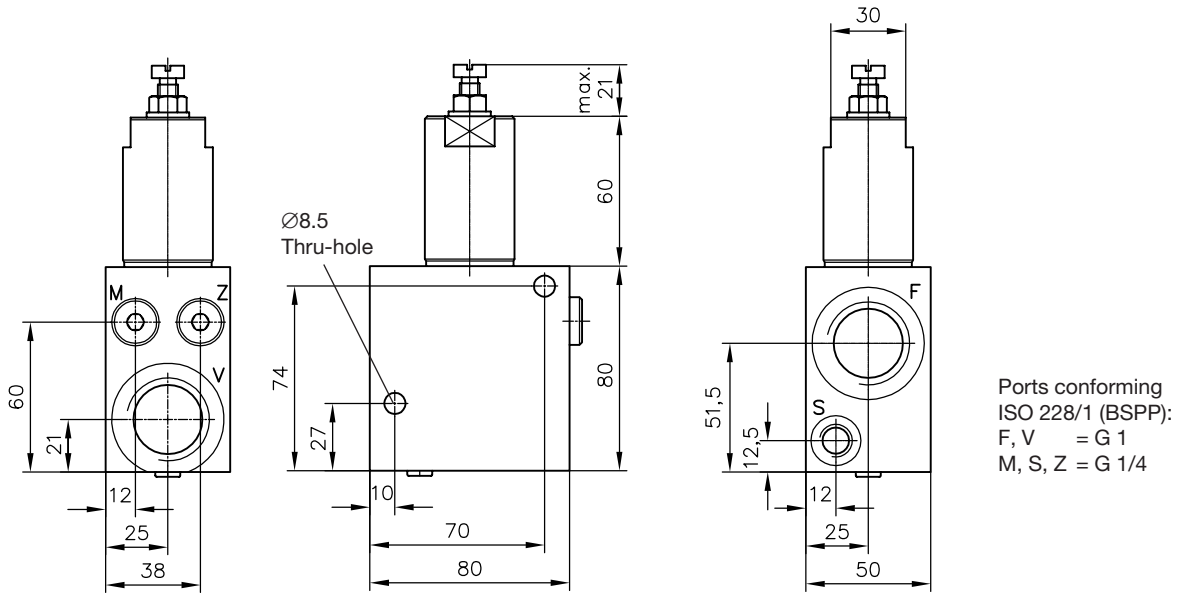

Type LHT 50 SAE-11

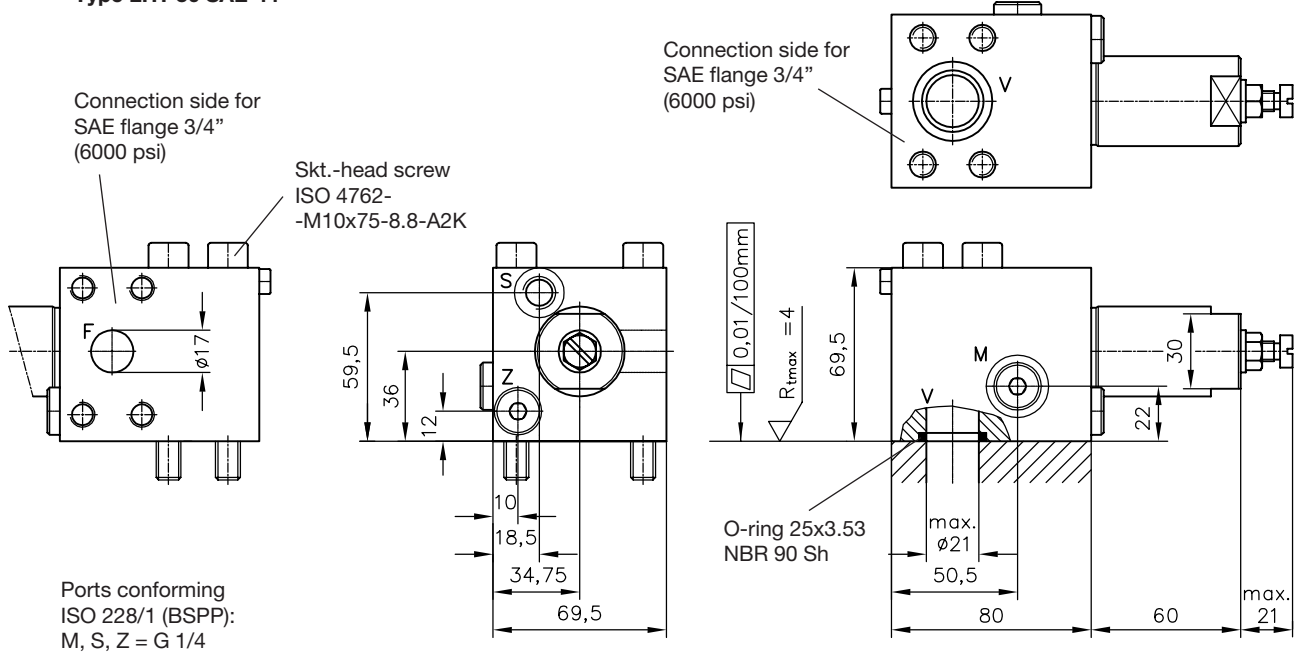

Flange enabling pipe connection at V SAE 3/4" (6000 psi)

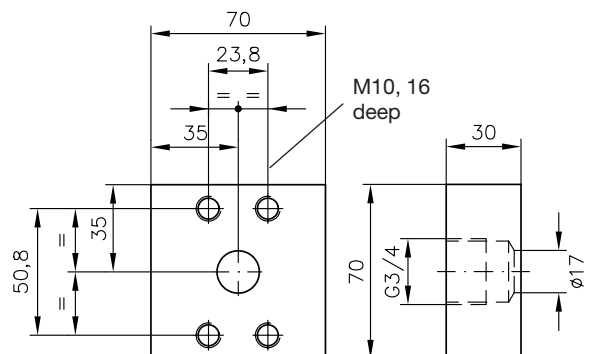

Type LHT 50 SAE-14

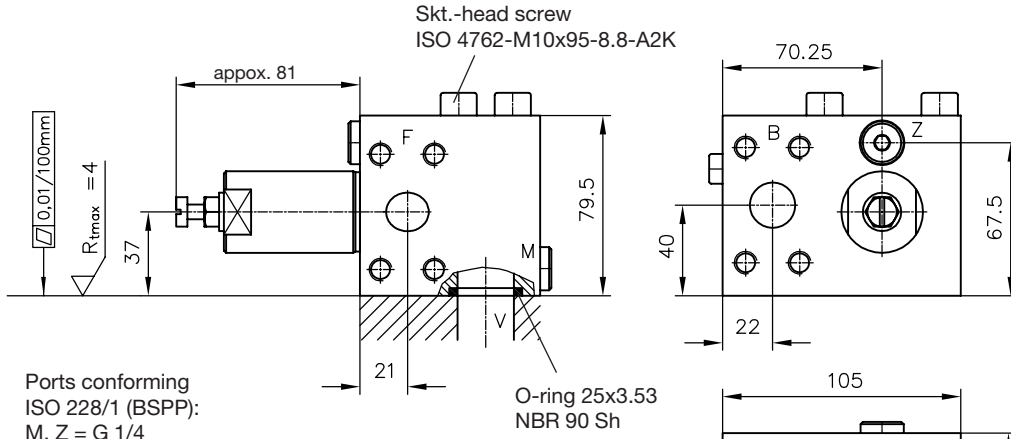

Ports conforming
ISO 228/1 (BSPP):
M, Z = G 1/4

Flange A, B, and F SAE 3/4" (6000 psi)

Flange enabling pipe connection at V

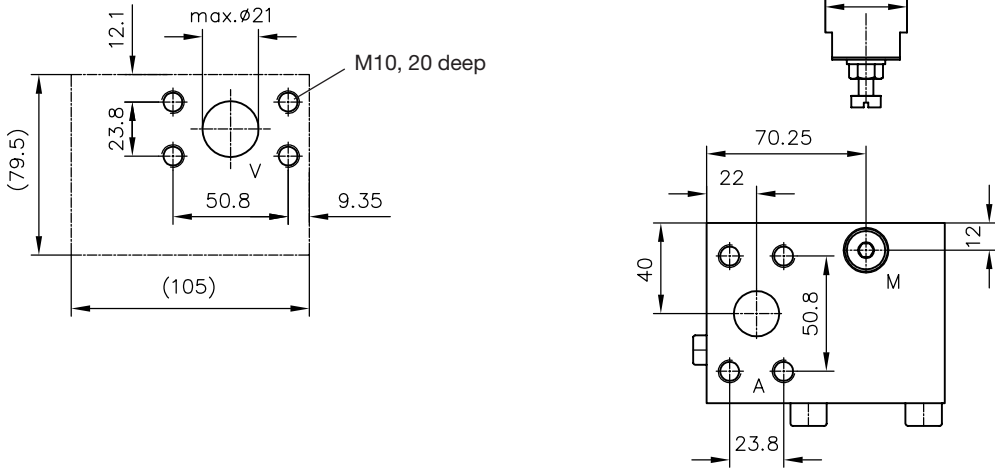

Type LHT 50 G-15

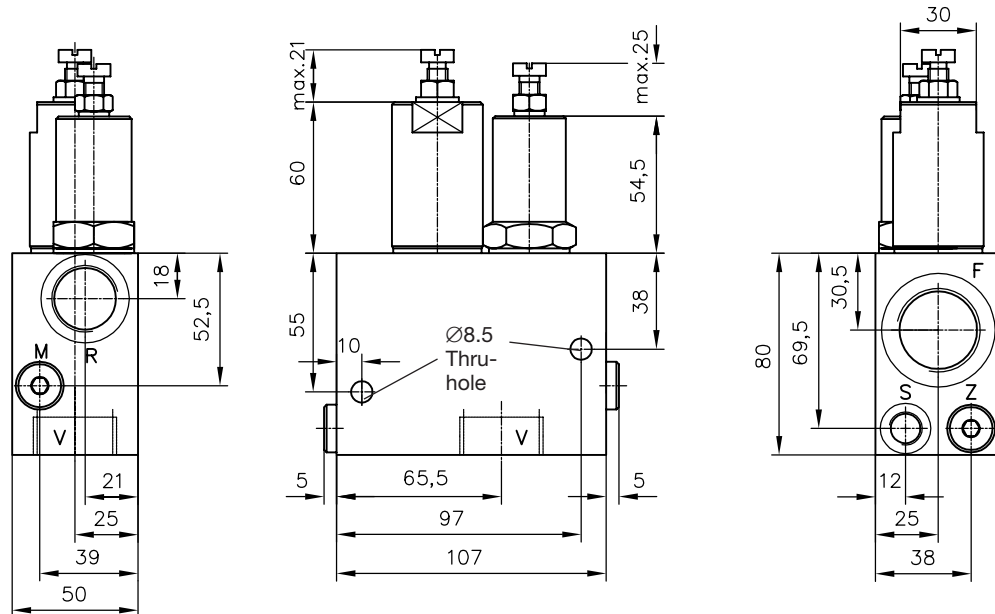

Ports conforming ISO 228/1 (BSPP):

- F, V = G 1
- R = G 3/4
- M, S, Z = G 1/4

Type LHT 50 SAE-15

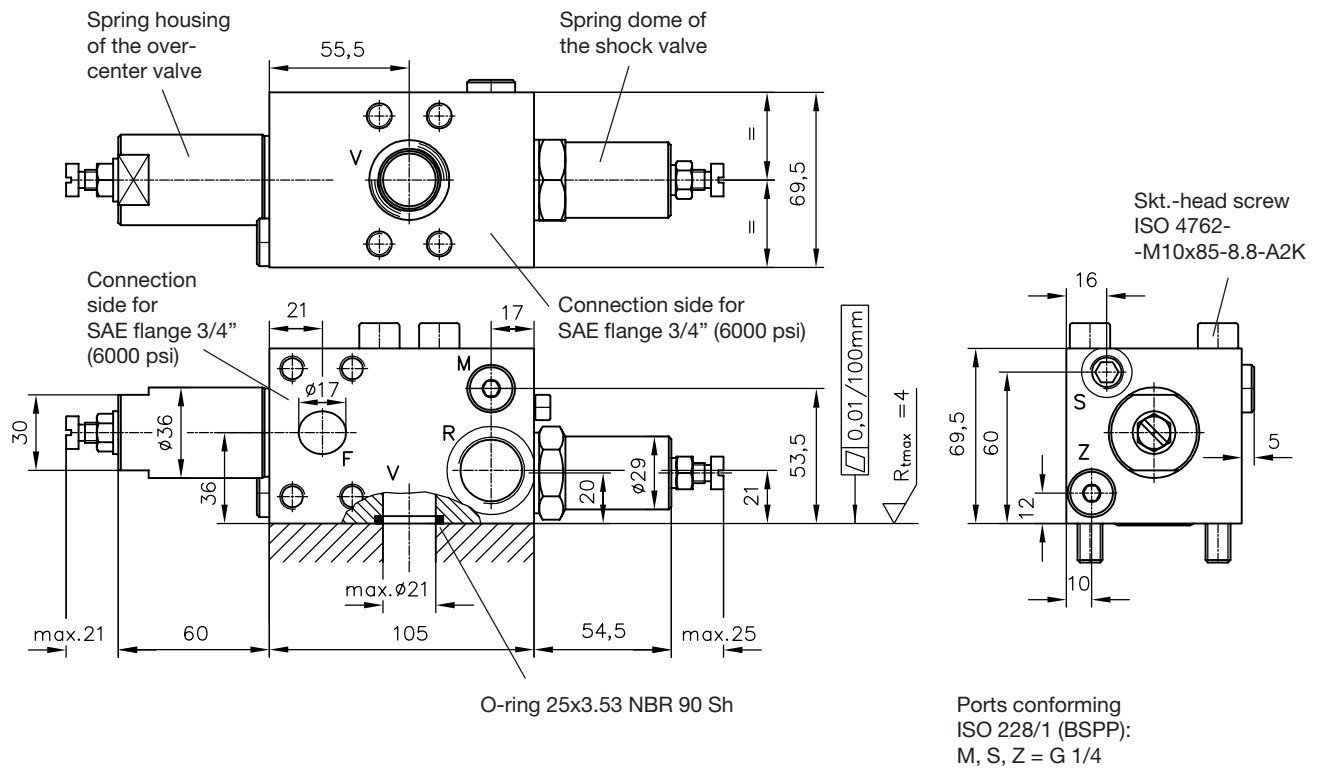

Flange enabling pipe connection at V SAE 3/4" (6000 psi)

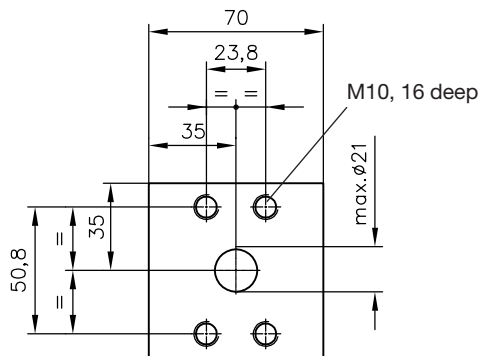

4.2 Cartridge valve Typ LHT 3E

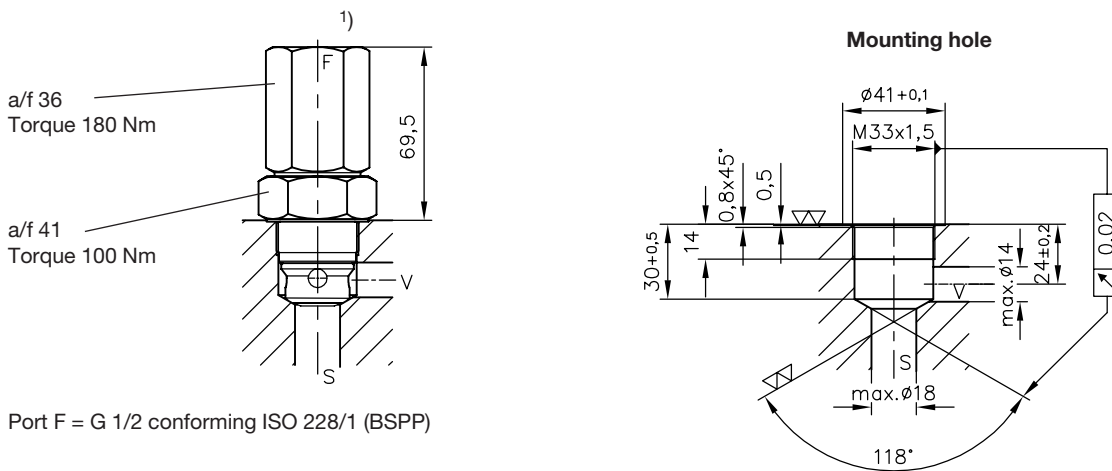

1) **Attention:**
The hexagonal spring housing must be countered while installing the pipe fitting !

5. Example circuit

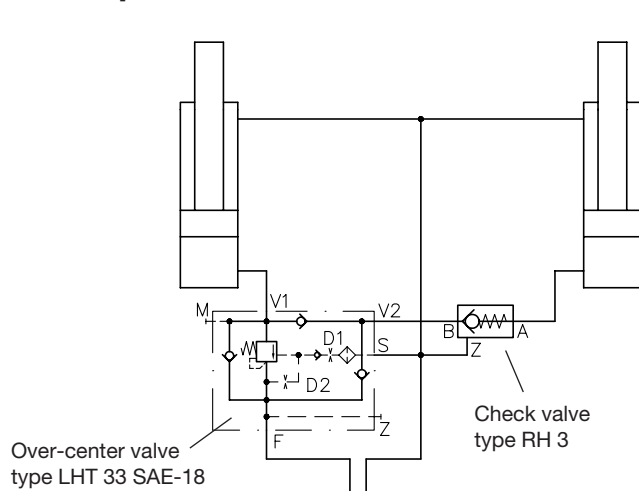

Over-center valve
type LHT 33 SAE-18

Check valve
type RH 3

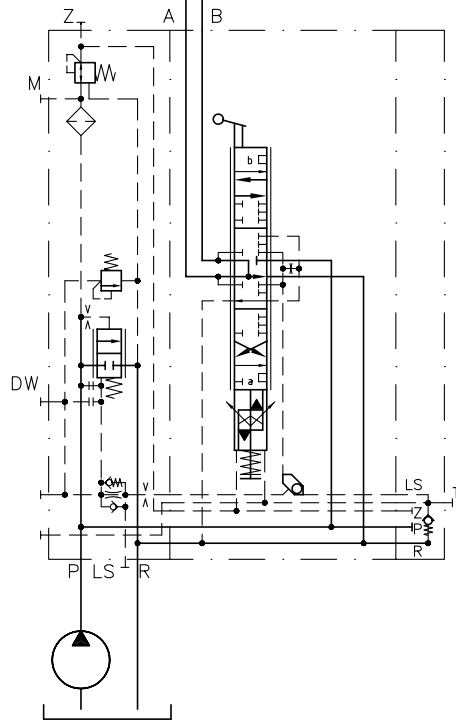

Proportional directional spool valve
type PSL 51/400 - 3 - H80/40/EA
- E4 - G 24

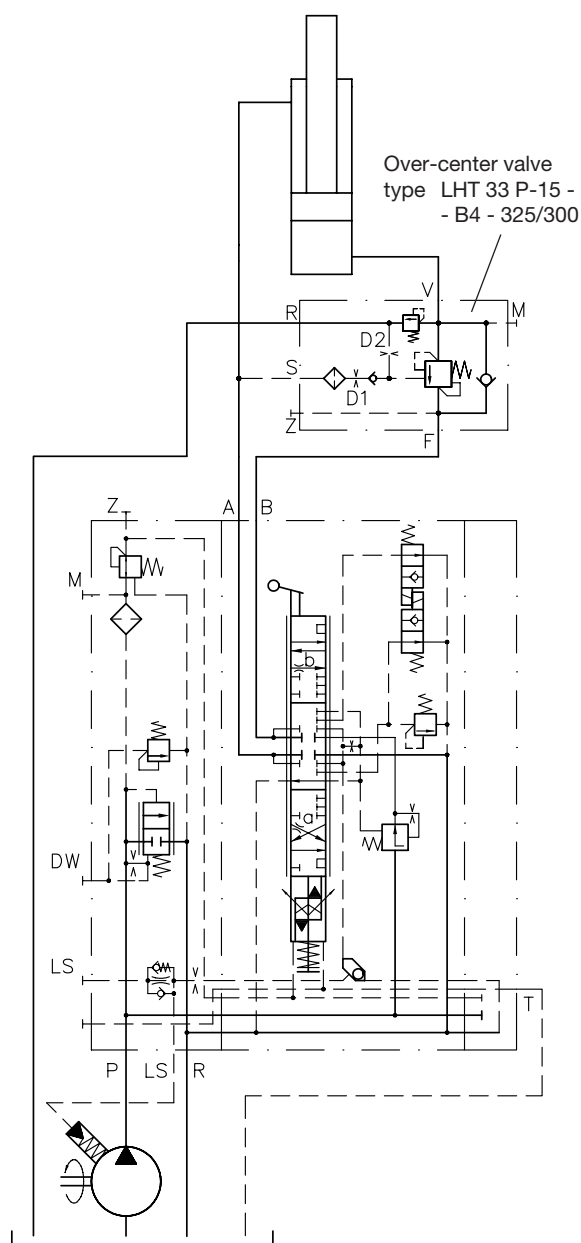

Over-center valve
type LHT 33 P-15 -
- B4 - 325/300

Proportional directional spool valve
type PSV 55S1/250 - 3 - J25/60 A100 F3 / EA
- E1 - G 24